

QUASER

we cut faster

MF SERIES

01 - 02	<i>Workpiece size & Machine structure</i>
03 - 04	<i>Cutting area and interference</i>
05 - 06	<i>Application sample</i>
07	<i>Unique spindle technology</i>
08	<i>Two axes table (4/5 axis)</i>
09 - 10	<i>ATC system</i>
11 - 12	<i>MF400 Cell & MF500 Cell</i>
13 - 14	<i>Easy operation</i>
15 - 16	<i>Coolant system & chip management</i>
17 - 18	<i>Technical data</i>
19	<i>Standard / Option accessories</i>
20 - 21	<i>Layout</i>
22	<i>We build machines in a hybrid way</i>

**C type: 5 axes positioning/
4 axes simultaneously**

- QUASER mill i
- SIEMENS 828D
- MITSUBISHI M830

U type: 5 axes simultaneously

- FANUC 31iB5*
- SIEMENS 840D
- HEIDENHAIN TNC640

Note: * The applying process of 5-axis controller is complicated and the lead time is longer than 6 months.

- The object might be different from the photos of catalogue if there is any specification update.

MF400

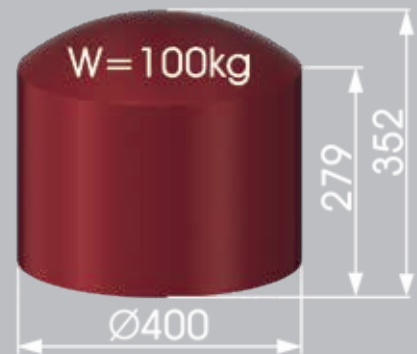

MF500

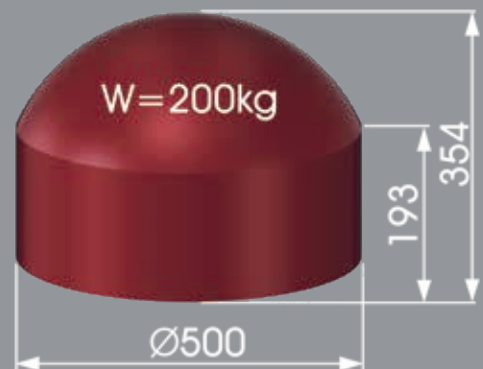

MF630

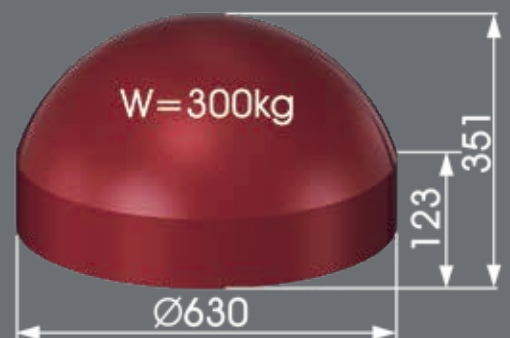

Machine structure



Cutting area and interference

MF400

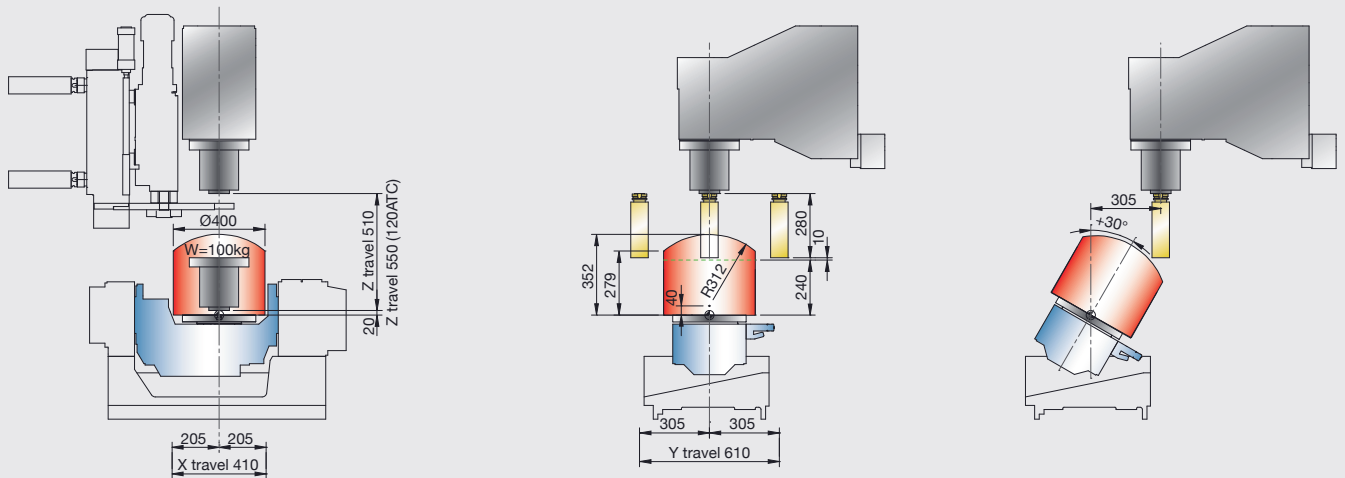

MF500

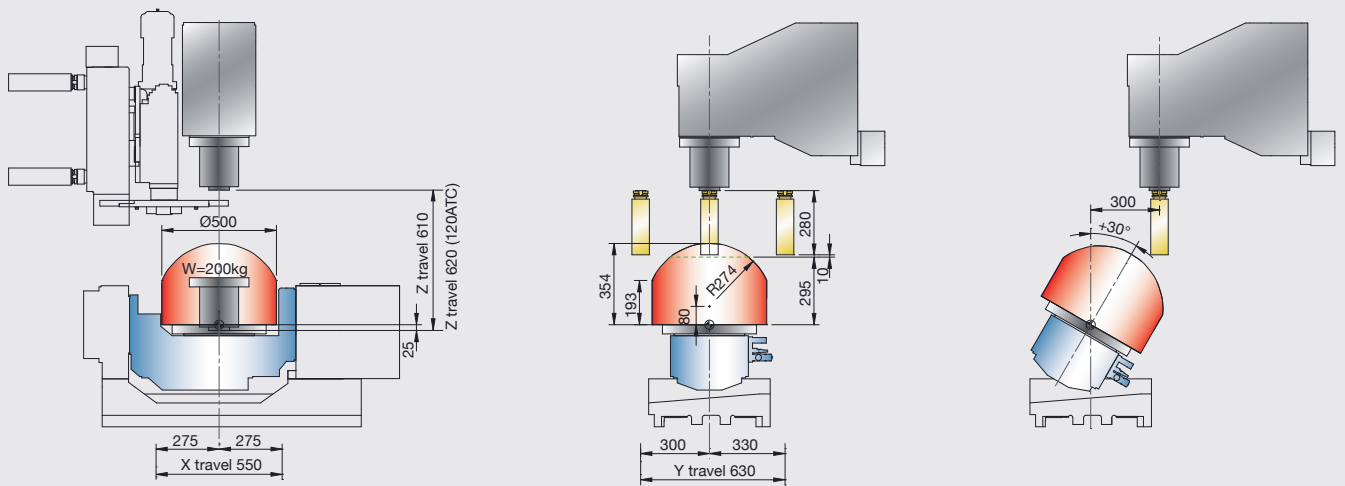

MF630

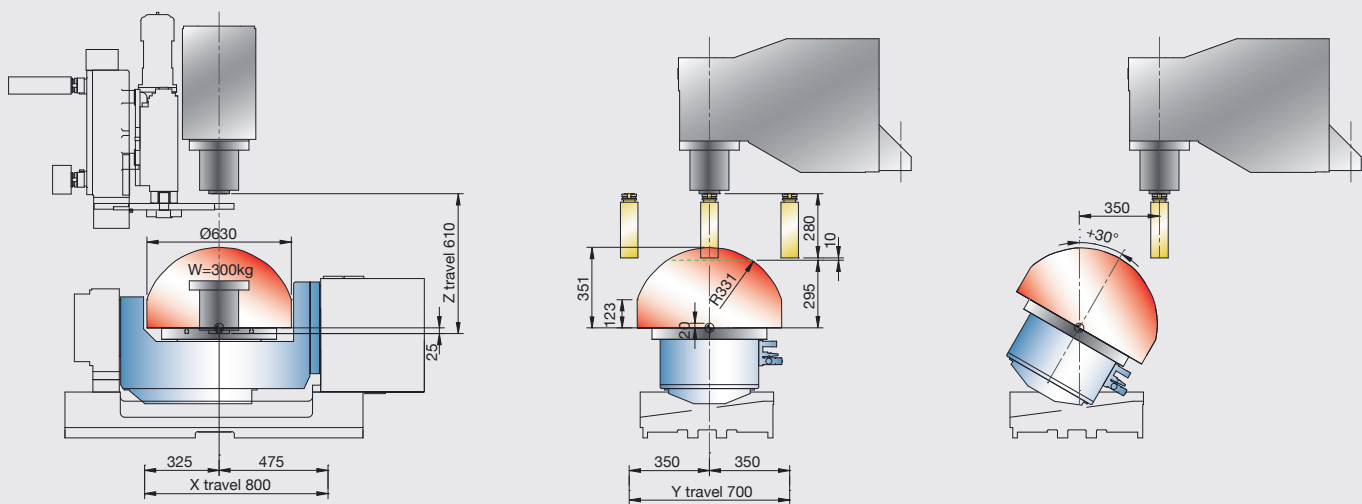

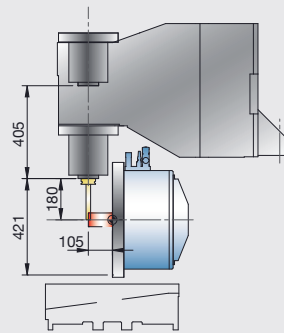
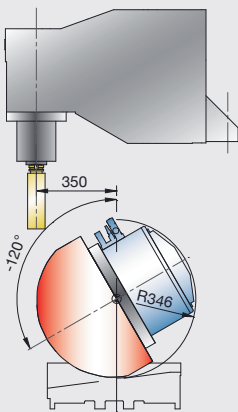
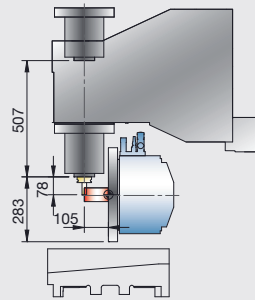
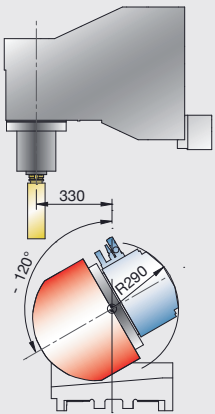
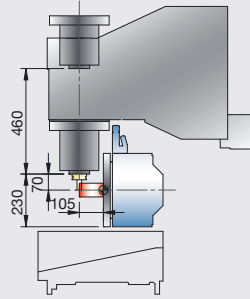
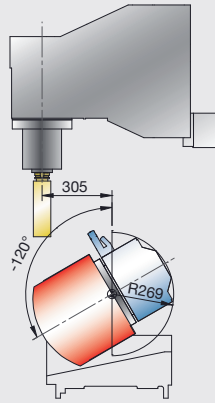

Application sample

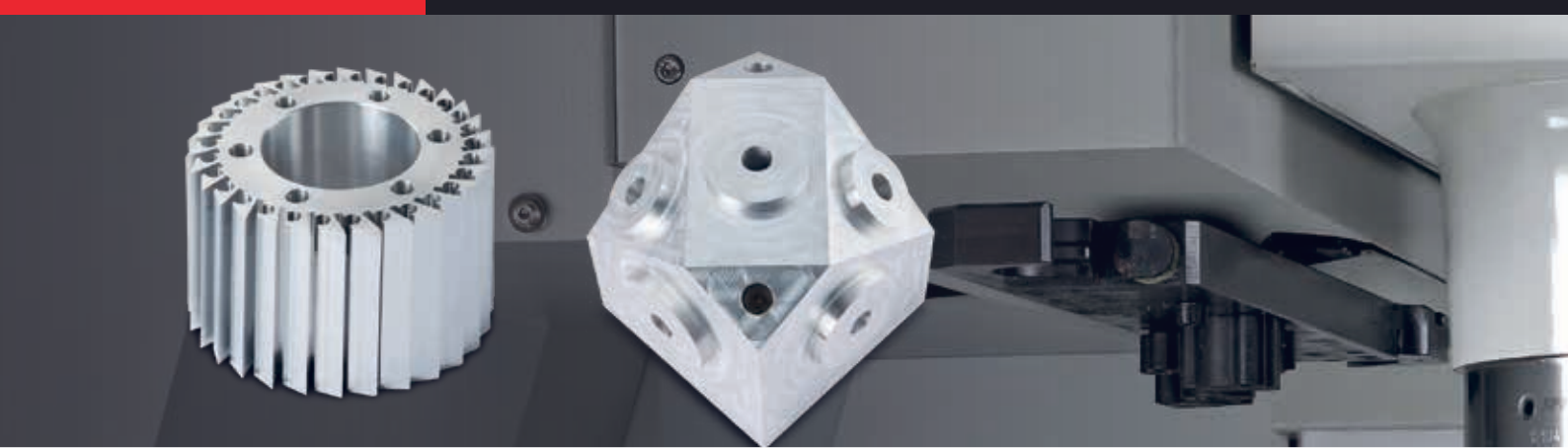

FANUC = **F** SIEMENS = **S** MITSUBISHI = **M**

Motor power	MF400C			MF500C			MF630C			
	SC-4.2	MC-4.1R	MC-4.0R	SC-4.2	MC-4.1R	MC-4.0 R	SC-4.2	MC-4.1R	MC-4.0R	
X / Y / Z (kW)	F	1.8 / 1.8 / 2.5	3 / 3 / 4		1.8 / 3 / 2.5	3 / 3 / 4		4 / 4 / 4		
	S	2.7 / 2.7 / 3.1		-	2.7 / 4.9 / 3.1		-	4.3 / 4.9 / 4.3		-
	M	2.2 / 3 / 3		-	2.2 / 3 / 3		-	3.5 / 3.5 / 3.5		-
A / C (kW)	F	1.8 / 1.2			2.5 / 1.8			2.5 / 1.8		
	S	2.3 / 1.5		-	3.1 / 2.3		-	3.1 / 2.3		-
	M	2.2 / 1.5		-	2 / 1.5		-	2.2 / 2.2		-

FANUC = **F** HEIDENHAIN = **H** SIEMENS = **S**

Motor power	MF400U			MF500U			MF630U			
	SC-4.2	MC-4.1R	MC-4.0R	SC-4.2	MC-4.1R	MC-4.0R	SC-4.2	MC-4.1R	MC-4.0R	
X / Y / Z (kW)	F	3 / 3 / 4			3 / 4 / 4			4 / 4 / 4		
	S	2.7 / 2.7 / 3.1		-	2.7 / 4.9 / 3.1		-	4.3 / 4.9 / 4.3		-
	H	4.5 / 5.1 / 5.1		-	4.5 / 5.1 / 5.1		-	5.1 / 5.1 / 8.6		-
A / C (kW)	F	2.7 / 2.5			4.5 / 2.7			4.5 / 2.7		
	S	2.3 / 1.5		-	3.1 / 2.3		-	3.1 / 2.3		-
	H	2.4 / 1.7		-	4.5 / 2.4		-	4.5 / 2.4		-



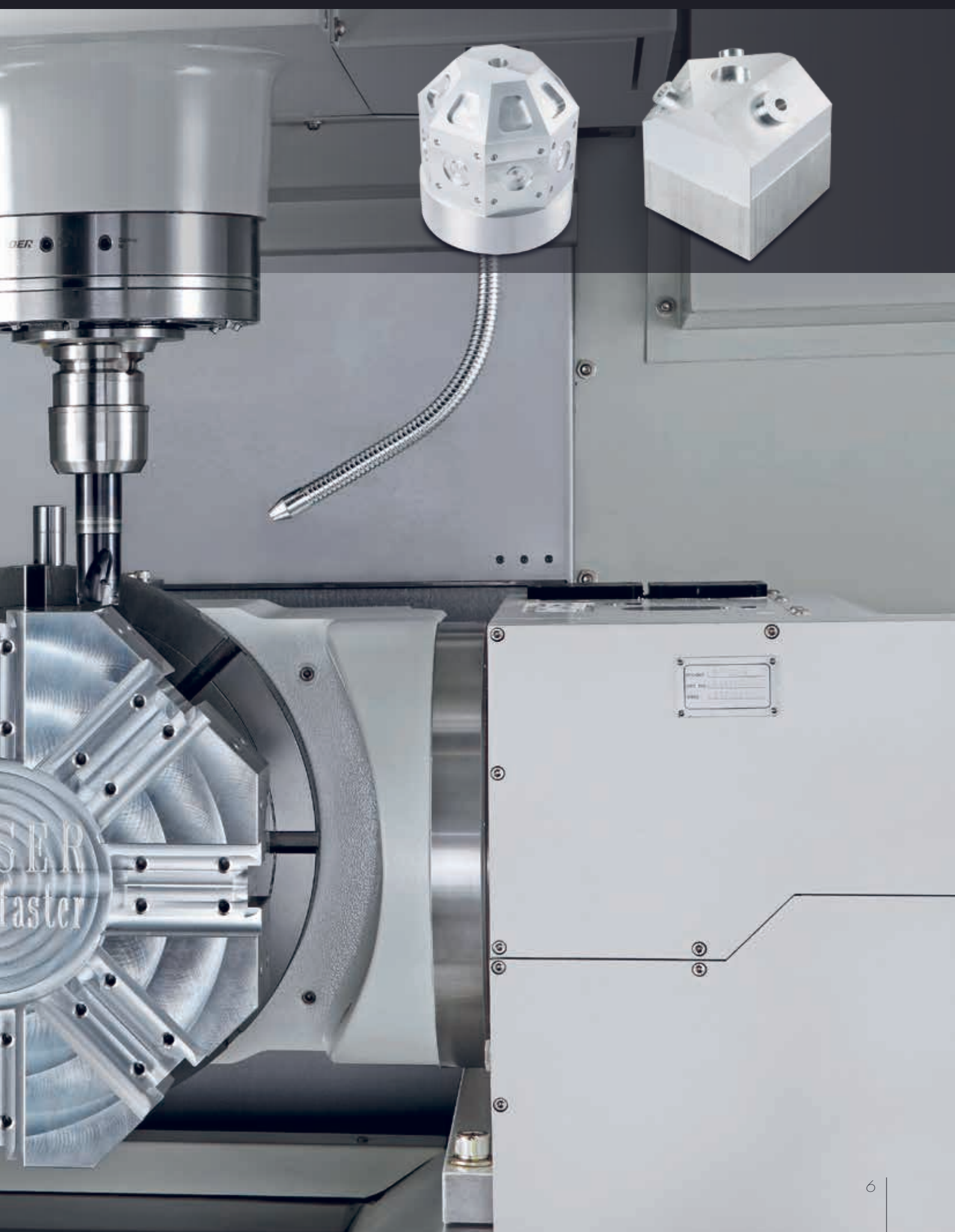

Unique spindle technology



Spindle code: SC-4.2
 Transmission: Coupling
 - Speed range:
 10,000 & 12,000 min⁻¹
 - Lubrication:
 Grease packed system
 - 4 ball bearing



MC-4.1R
 Coupling

15,000 min⁻¹

Re-grease system
 2 Angular contact ceramic bearing, 1 Cylindrical roller steel bearing

MC-4.0R
 Coupling

20,000 min⁻¹

Re-grease system
 2 Angular contact ceramic bearing, 1 Cylindrical roller ceramic bearing

Control: FANUC = ● SIEMENS = ● MITSUBISHI = ● HEIDENHAIN = ●

SPINDLE	SC-4.2						MC-4.1R	MC-4.0R
Max. spindle speed (min ⁻¹)	10,000	12,000					15,000	20,000
Spindle transmission	Coupling						Coupling	Coupling
Spindle diameter (mm)	Ø70						Ø80 / Ø65	Ø70 / Ø60
FANUC								
Spindle base speed	-	1,350	1,500			1,400	1,500	
Spindle output power kW (S3-25%)	-	18.5	15			26	15	
Spindle output torque Nm (S3-25%)	-	118	95.5			177	125	
SIEMENS								
Spindle base speed	-	1,500		1,500		2,000	-	
Spindle output power kW (S6-25%)	-	13.3	17.6 ⁽¹⁾	13.3	17.6 ⁽¹⁾	27.7	-	
Spindle output torque Nm (S6-25%)	-	85	112 ⁽¹⁾	85	112 ⁽¹⁾	132	-	
MITSUBISHI								
Spindle base speed	1,500	1,500	1,400	1,500	1,400	-	-	
Spindle output power kW (30min.)	15	11	18.5	11	18.5	-	-	
Spindle output torque Nm (30min.)	96	70	102	70	102	-	-	
HEIDENHAIN								
Spindle base speed	-	1,500		1,500		2,000	-	
Spindle output power kW (S6-25%)	-	17	32	17	32	27.7	-	
Spindle output torque Nm (S6-25%)	-	108	204	108	204	132	-	
CTS Available	X	X		○		○	○	
Model								
MF400C	●	●●●	-	●●●	-	●●	●	
MF400U	-	●●●	-	●●●	-	●●●	●	
MF500C	●	●●●	-	●●●	-	●●	●	
MF500U	-	●●●	-	●●●	-	●●●	●	
MF630C	●	-	●●●	-	●●	●●	●	
MF630U	-	-	●●●	-	●●	●●●	●	

Note: The standard specification for MF series as 12C + Oil chiller but except MITSUBISH control ⁽¹⁾S6-40%

Two axes table (4/5 axis)

Combining alloy steel and aluminum bronze greatly reduces friction coefficient, effectively transmitting motor torque.



Work envelope	MF400		MF500		MF630	
	Rotary Axis (C-axis)	Tilting Axis (A-axis)	Rotary Axis (C-axis)	Tilting Axis (A-axis)	Rotary Axis (C-axis)	Tilting Axis (A-axis)
Max. swing (mm)	Ø400		Ø500		Ø630	
Table load capacity (kg)	100 (110 Nm)		200 (200 Nm)		300 (300 Nm)	
Maximum R.P.M (min ⁻¹)	25	25	16.6	11.1	16.6	11.1
Indexing accuracy (sec.)	20 (12)	12	20 (12)	12	20 (12)	12
Repeatability (sec.)	10 (4)	5	10 (4)	5	12 (5)	8
Clamping torque (Nm)	750	1,500	1,600	2,000	2,500	3,000

Note: () with rotary encoder

Cutting force limitation

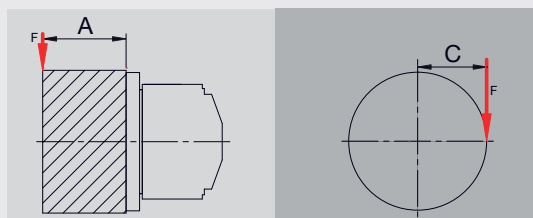

MF400

MF500

MF630

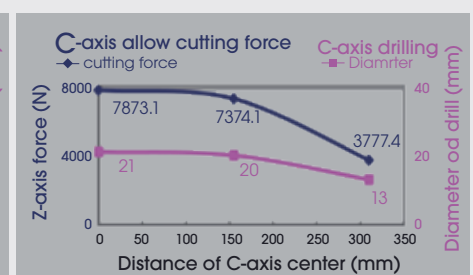
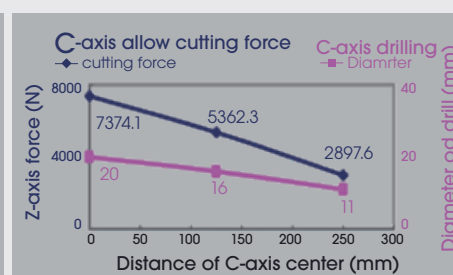
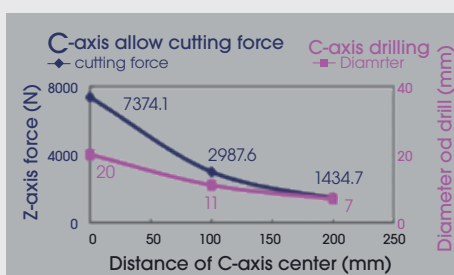
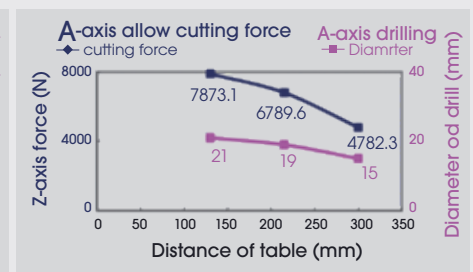
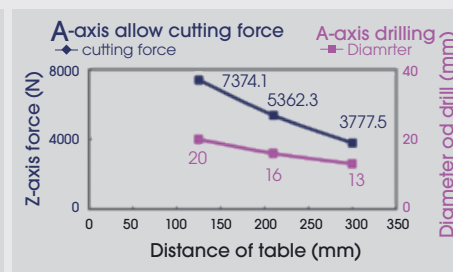
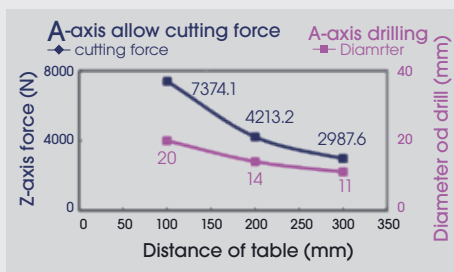

ATC system

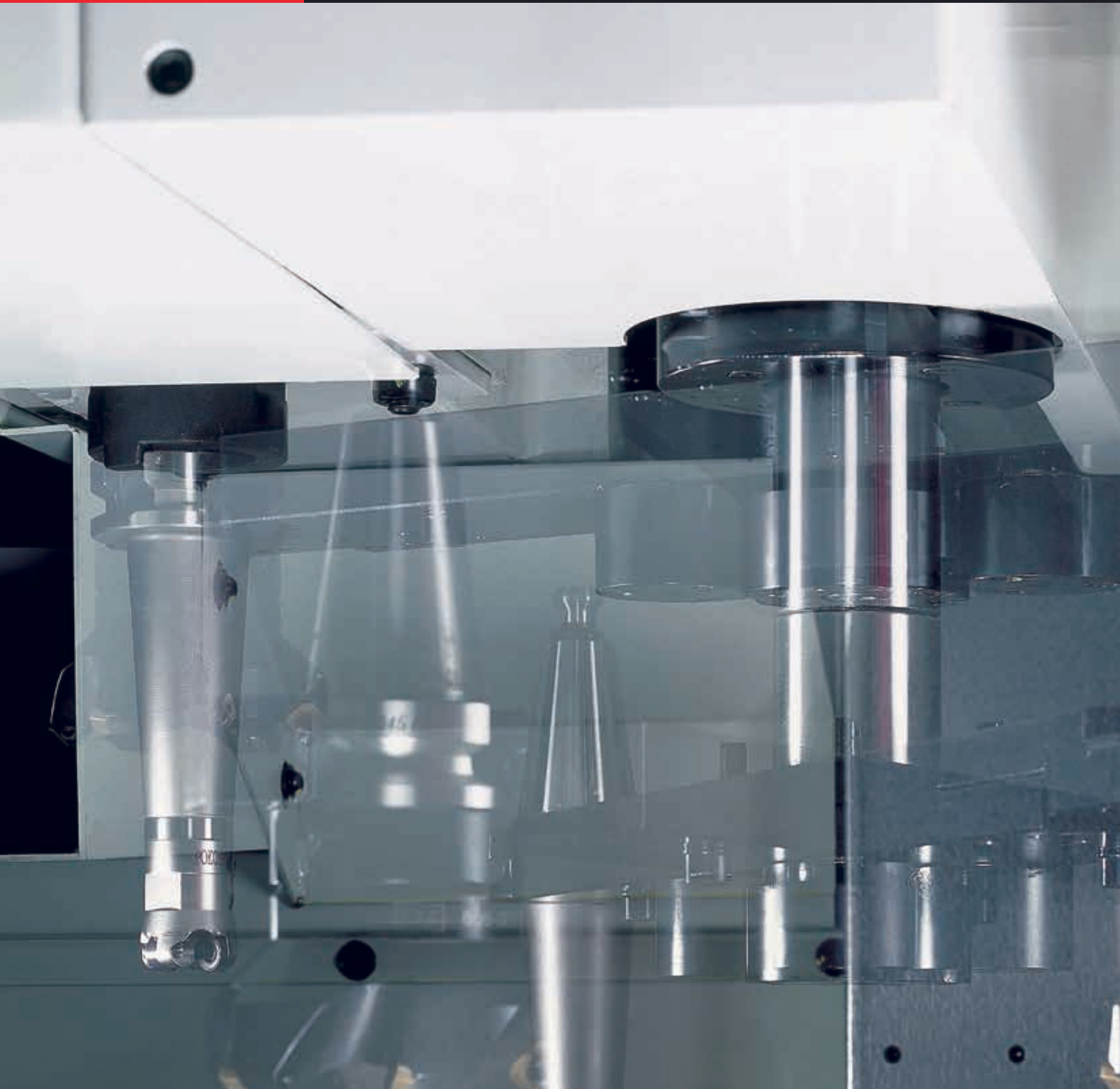

30 ATC (std.)

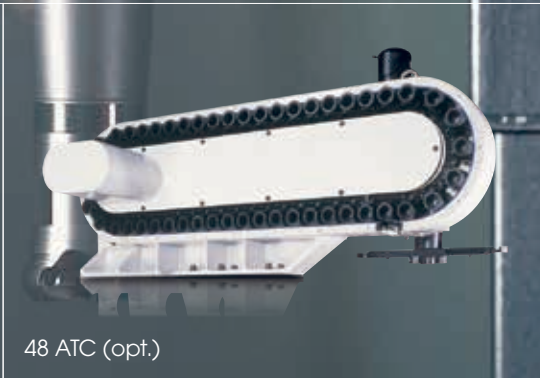

48 ATC (opt.)



60 ATC (opt.)

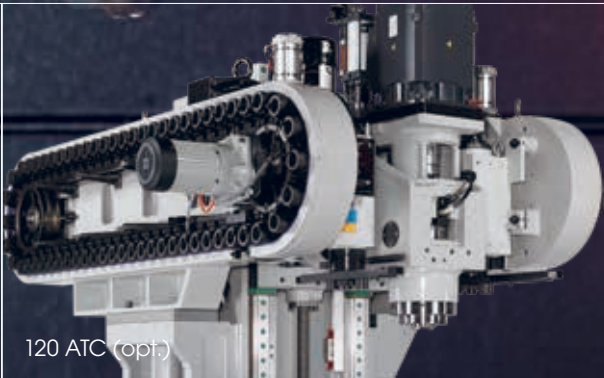
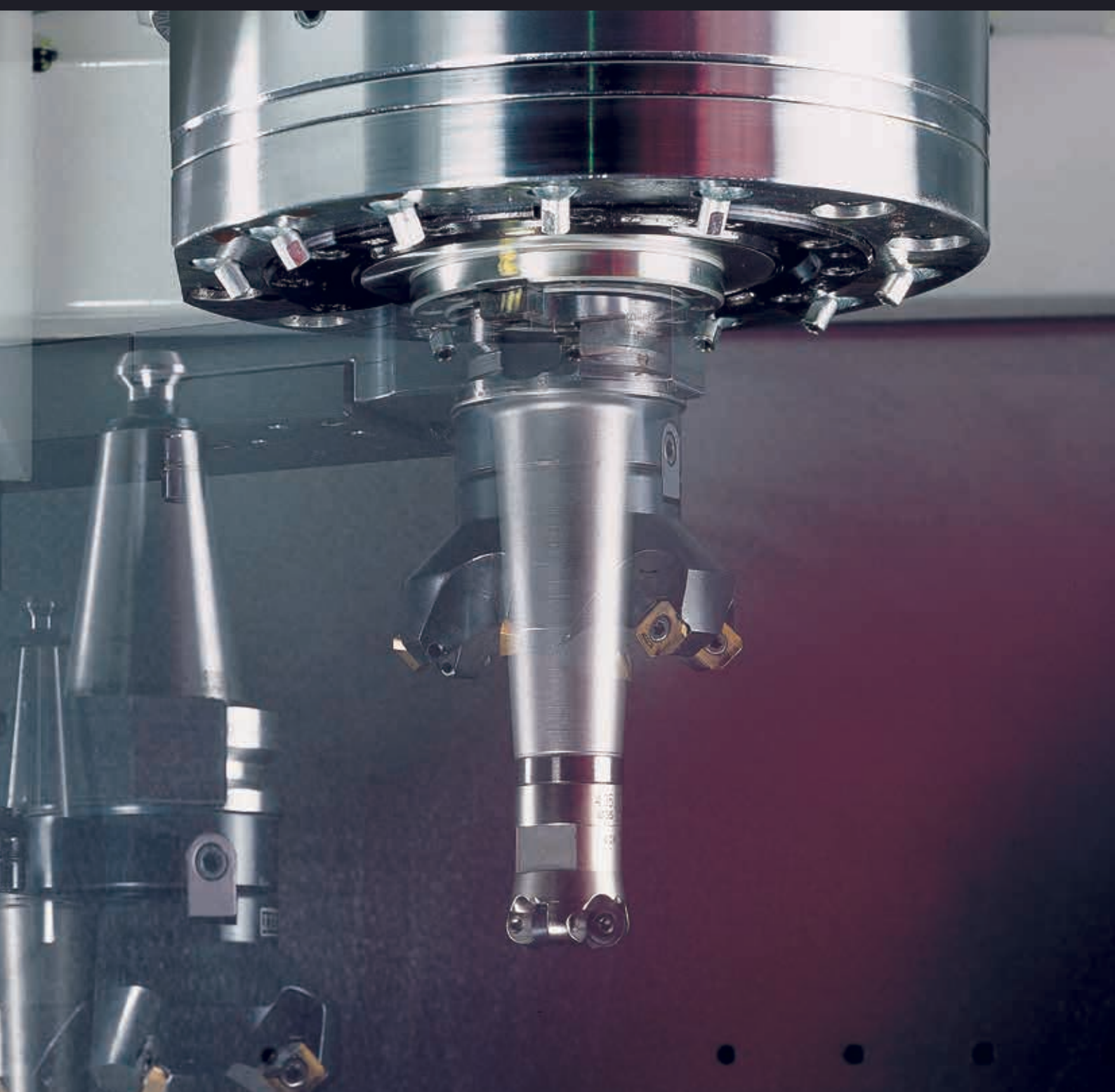

120 ATC (opt.)



ATC auto door (opt.)

MF400 Cell & MF500 Cell

MF400 : Pallet size: \square 265 (mm)
Travel X / Y / Z: 680 / 610 / 510 (mm)
Max. ATC capacity:120
Pallet capacity: 40

MF500 : Pallet size: \square 350 (mm)
Travel X / Y / Z: 550 / 630 / 610 (mm)
Max. ATC capacity:120
Pallet capacity: 28

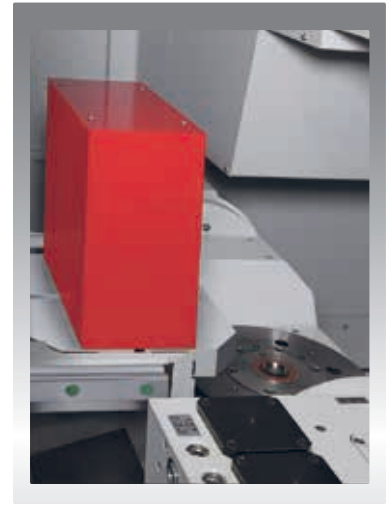

pallet clamping system

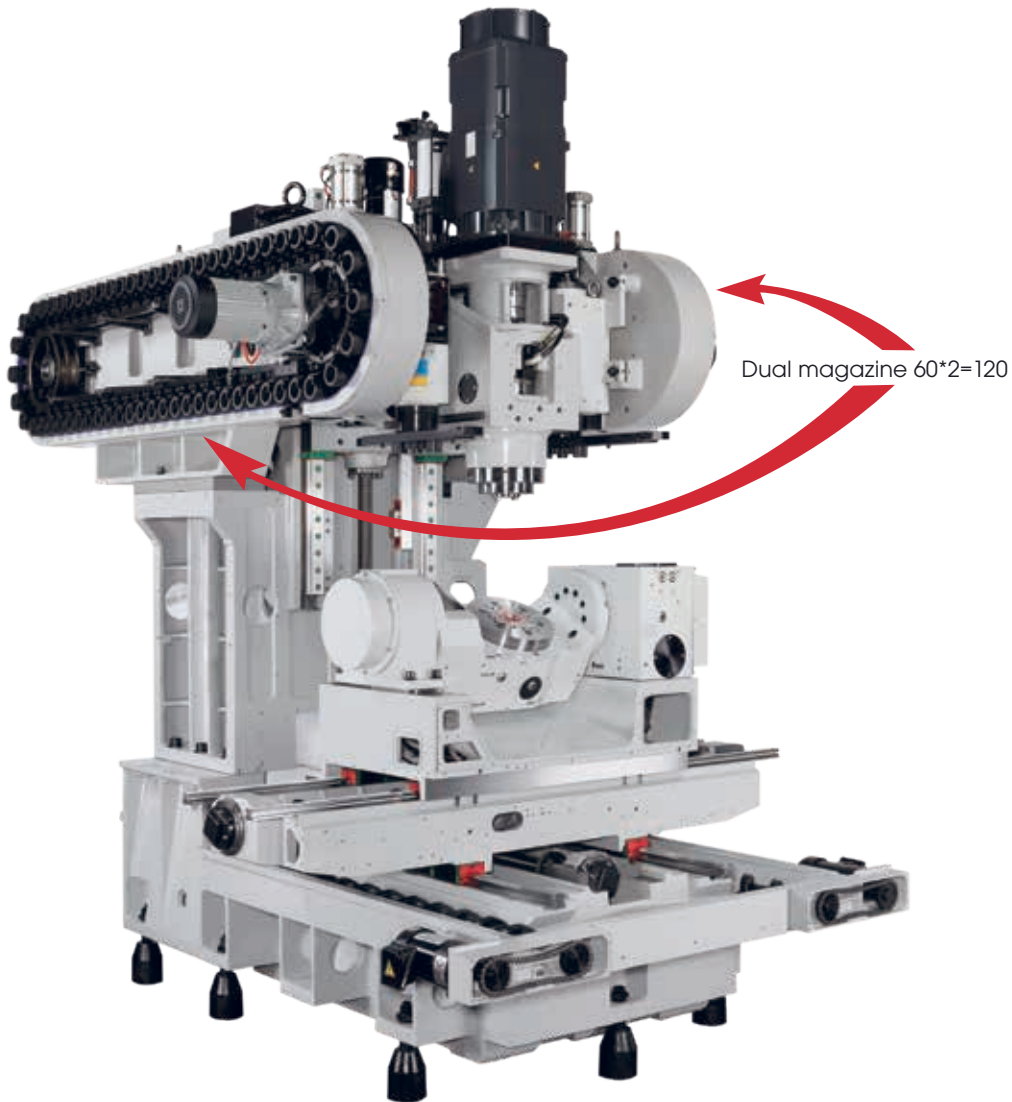



Pallet storage tower



Pallet loader



System controller



Note: Find details in MF M/C Cell.

Easy operation

- a** From center of table to operator door
 - MF400: 605 mm
 - MF500: 605 mm
 - MF630: 540 mm
- b** Max. size when operator door open
 - MF400: 870 mm
 - MF500: 870 mm
 - MF630: 1,400 mm
- c** Documentation & hand tool shelf
- d** Swivel type operation panel
- e** Hand held remote MPG



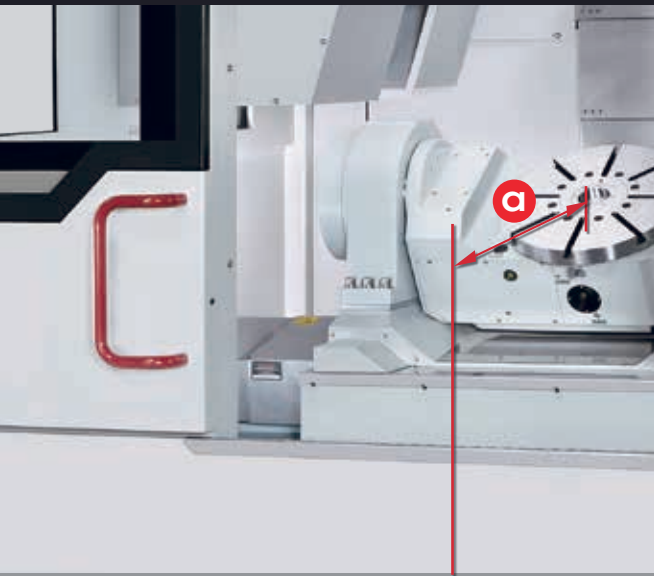

Coolant system & Chip management

- a** Coolant tank
 - MF400 / MF500 / MF630: 300 / 300 / 600 Liter
 - Nozzle coolant: 3~3.5 bar
 - Wash down: 3~4.5 bar
- b** External chip conveyor (opt.)
- c** Internal chip augers
- d** Wash gun





Model MF500U

Technical Data		MF400C MF400U			
Spindle code		10C	12C	15C	20C*
Work range					
Table size (mm)		Ø320			
Travel	X / Y / Z (mm)	410 / 610 / 510 ⁽¹⁾			
	A (degree)	+30° ~ -120°			
	C (degree)	360° (Continuous)			
Max. swing (mm)		Ø400			
Table surface to spindle nose (mm)		20 ~ 530			
Spindle nose to tilting center (mm)		20 ~ 530			
Max. work piece size (mm)		Ø400 x 300			
Table load capacity (kg)		100 (110 Nm)			
Feed drive					
Feed force	X / Y / Z (N)	6,283 / 11,781 / 11,781 (M)	5,760 / 5,760 / 10,472 (F)	6,283 / 6,283 / 11,519 (F)	
			6,283 / 6,283 / 15,708 (S)	6,283 / 6,283 / 15,708 (S)	
			6,283 / 11,781 / 11,781 (M)	6,283 / 6,283 / 11,519 (F)	
			6,283 / 6,283 / 15,708 (S)	6,283 / 6,283 / 15,708 (S)	
			9,267 / 11,310 / 16,965 (T)	9,267 / 11,310 / 16,965 (T)	
Rapid movement	X / Y / Z (m/min.)	36 / 36 / 24			
		A=25 / C=25			
Acceleration	X / Y / Z (m/s ²)	3 / 3 / 2 (M)	3 / 3 / 2 (F; M; T) 3 / 2 / 2 (S)		
Accuracy Positioning / Repeatability					
ISO 230-2		0.008 / 0.004			
JIS 6338 (300 mm)		±0.003 / ±0.002			
VDI3441		0.008 / 0.004			
Main spindle					
Spindle taper		BBT40			
Tool changer					
Tool selection		Random			
Magazine positions		30 (std.) 48 / 60 / 120 (opt.)			
Max. tool diameter (mm)		76.2			
w/o adjacent tool (mm)		125			
Max. tool length (mm)		280			
Max. tool weight (kg)		7			
CTC time – ISO 10791-9 (sec.)		4.2 (M)	4.2 (F; M; T) 4.4 (S)		
Coolant system					
Coolant tank capacity (Liter)		300			
Pump capacity					
- Nozzle coolant		75L / min., 3 bar			
- Wash down		75L / min., 3 bar			
Machine size					
Height (mm)		3,070		3,140	
Floor space W x D (mm)	30 / 48ATC	2,020 x 2,820			
	60ATC	2,020 x 3,160			
Weight (kg)		7,300 (30ATC) 7,600 (48ATC) 7,800 (60ATC) 8,670 (120ATC)			
Connections					
Main power		220V or 380V or 400V or 415V / 50Hz or 60Hz			
Power consumption (KVA)		26 (M)	24 (F) 21 (S; M) 28 (F; T) 21 (S)	32.5 (F) 31 (S) 34 (F) 21 (S) 34 (T)	31 (F) 32 (F)

Note: ⁽¹⁾ Option 120 ATC Z axis travel 550 ⁽²⁾ Option 120 ATC Z axis travel 620 * Only for FANUC control

MF500C MF500U				MF630C MF630U			
10C	12C	15C	20C*	10C	12C	15C	20C*
Ø410				Ø500			
550 / 630 / 610 ⁽²⁾				800 / 700 / 610			
+30° ~ -120°				+30° ~ -120°			
360° (Continuous)				360° (Continuous)			
Ø500				Ø630			
-25 ~ 585				-25 ~ 585			
-25 ~ 585				-25 ~ 585			
Ø500 x 300				Ø630 x 300			
200 (200 Nm)				300 (300 Nm)			
6,283 / 11,781 / 11,781 (M)	5,760 / 10,472 / 10,472 (F)	6,283 / 6,283 / 11,519 (F)		11,781 / 11,781 / 17,671 (M)	11,519 / 11,519 / 17,279 (F)	11,519 / 11,519 / 17,279 (F)	
	6,283 / 14,137 / 15,708 (S)	6,283 / 14,137 / 15,708 (S)			14,137 / 14,137 / 21,206 (S)	14,137 / 14,137 / 21,206 (S)	
	6,283 / 11,781 / 11,781 (M)				11,781 / 11,781 / 17,671 (M)		
	6,283 / 11,519 / 11,519 (F)	6,283 / 11,519 / 11,519 (F)			11,519 / 11,519 / 17,279 (F)	11,519 / 11,519 / 17,279 (F)	
	6,283 / 14,137 / 15,708 (S)	6,283 / 14,137 / 15,708 (S)			14,137 / 14,137 / 21,206 (S)	14,137 / 14,137 / 21,206 (S)	
	9,267 / 11,310 / 16,965 (T)	9,267 / 11,310 / 16,965 (T)			11,310 / 11,310 / 29,845 (T)	11,310 / 11,310 / 29,845 (T)	
36 / 36 / 24				32 / 32 / 16			
A=11.1 / C=16.6				A=11.1 / C=16.6			
3 / 3 / 2				3 / 3 / 2			

0.008 / 0.004

±0.003 / ±0.002

0.008 / 0.004

BBT40

Random

30 (std.) 48 / 60 / 120 (opt.)				30 (std.) 48 / 60 (opt.)			
76.2				76.2			
125				125			
280				280			
7				7			
4.2 (M)	4.2 (F) 4.4 (S) 4.2 (T)			6.2			
300				600			
75L / min., 3 bar				60L / min., 3.5 bar			
75L / min., 3 bar				60L / min., 4.5 bar			
3,105		3,175		3,230		3,380	
2,280 x 3,225				3,705 x 2,530 (30ATC) 3,705 x 2,870 (48ATC)			
2,280 x 3,610				3,705 x 3,250			
7,480 (30ATC) 7,780 (48ATC) 7,980 (60ATC) 8,850 (120ATC)				8,750 (30ATC) 9,050 (48ATC) 9,250 (60ATC)			

220V or 380V or 400V or 415V / 50Hz or 60Hz

26 (M)	26 (F) 25 (S) 21 (M)	33 (F) 32 (S)	31 (F)	28 (M)	28 (F) 35 (S) 32 (M)	34.7 (F) 35 (S)	32 (F)
	29 (F) 25 (S)	36 (F) 32 (S)			33 (F)	31 (F) 35 (S) 36 (T)	
		34 (T)				36 (T)	

Standard / Option accessories	MF400C / MF400U				MF500C / MF500U				MF630C / MF630U			
Spindle code	10C	12C	15C	20C	10C	12C	15C	20C	10C	12C	15C	20C
■ SIEMENS 828D (5 Faces)	✕	○/✕	○/✕	✕	✕	○/✕	○/✕	✕	✕	○/✕	○/✕	✕
■ QUASER mill i (5 Faces)	✕	●/✕	○/✕	○/✕	✕	●/✕	○/✕	○/✕	✕	●/✕	○/✕	○/✕
■ MITSUBISHI M830 (5 Faces)	●/✕	○/✕	✕	✕	●/✕	○/✕	✕	✕	●/✕	○/✕	✕	✕
■ FANUC 31iB5 (5 Axes) ⁽¹⁾	✕	✕/○	✕/○	✕/○	✕	✕/○	✕/○	✕/○	✕	✕/○	✕/○	✕/○
■ SIEMENS 840D (5 Axes)	✕	✕/○	✕/○	✕	✕	✕/○	✕/○	✕	✕	✕/○	✕/○	✕
■ HEIDENHAIN TNC640 (5 Axes)	✕	✕/●	✕/○	✕	✕	✕/●	✕/○	✕	✕	✕/●	✕/○	✕
■ Oil chiller	●	●	●	●	●	●	●	●	●	●	●	●
■ 10,000 min ⁻¹ SC-4.2 coupling spindle	●/✕	✕	✕	✕	●/✕	✕	✕	✕	●/✕	✕	✕	✕
■ 12,000 min ⁻¹ SC-4.2 coupling spindle	✕	●/●	✕	✕	✕	●/●	✕	✕	✕	●/●	✕	✕
■ 15,000 min ⁻¹ MC-4.1R coupling spindle	✕	✕	●/●	✕	✕	✕	●/●	✕	✕	✕	●/●	✕
■ 20,000 min ⁻¹ MC-4.0R coupling spindle (FANUC only)	✕	✕	✕	●/●	✕	✕	✕	●/●	✕	✕	✕	●/●
■ 30 position tool magazine	●	●	●	●	●	●	●	●	●	●	●	●
■ 48 / 60 position tool magazine	○	○	○	○	○	○	○	○	○	○	○	○
■ 120 position tool magazine	○	○	○	○	○	○	○	○	✕	✕	✕	✕
■ Pull stud for BT tooling system	○	○	○	○	○	○	○	○	○	○	○	○
■ Balance tooling for spindle warm up	○	○	●	○	○	○	○	●	○	○	●	○
■ ATC auto door	○	○	○	○	○	○	○	○	○	○	○	○
■ Work probe receiver OMI-2T	●	●	●	●	●	●	●	●	●	●	●	●
■ Work probe OMP-40	○	○	○	○	○	○	○	○	○	○	○	○
■ Reference rod (for thermal comp with probe)	●	●	●	●	●	●	●	●	●	●	●	●
■ Tool length / breakage measurement	○	○	○	○	○	○	○	○	○	○	○	○
■ Hydraulic through pallet (2 ports)*	○	○	○	○	○	○	○	○	○	○	○	○
■ Air pressure detector for pallet clamping	○	○	○	○	○	○	○	○	○	○	○	○
■ X / Y / Z linear scale & C rotary encoder	○	○	○	○	○	○	○	○	○	○	○	○
■ Rotary encoder on A axes	○	○	○	○	○	○	○	○	○	○	○	○
■ Transformer	○	○	○	○	○	○	○	○	○	○	○	○
■ Coolant system	●	●	●	●	●	●	●	●	●	●	●	●
■ Coolant through spindle	F	✕	○	○	✕	○	○	○	✕	✕	○	○
	S	✕	○	○	✕	○	○	✕	✕	○	○	✕
	M	✕	○	✕	✕	○	✕	✕	✕	○	✕	✕
	T	✕	○	○	✕	○	○	✕	✕	○	○	✕
■ Coolant wash gun	●	●	●	●	●	●	●	●	●	●	●	●
■ Coolant wash down	●	●	●	●	●	●	●	●	●	●	●	●
■ External chip conveyor	○	○	○	○	○	○	○	○	○	○	○	○
■ Internal chip augers	●	●	●	●	●	●	●	●	●	●	●	●
■ Cutter air blast	●	●	●	●	●	●	●	●	●	●	●	●
■ Oil-mist collector	○	○	○	○	○	○	○	○	○	○	○	○
■ Bag filtration	○	○	○	○	○	○	○	○	○	○	○	○
■ Filtration unit	○	○	○	○	○	○	○	○	○	○	○	○
■ Documentation (CD-ROM) ⁽²⁾	●	●	●	●	●	●	●	●	●	●	●	●
■ Work light	●	●	●	●	●	●	●	●	●	●	●	●
■ Machine status light	●	●	●	●	●	●	●	●	●	●	●	●
■ CE & EMC / GB	○	○	○	○	○	○	○	○	○	○	○	○

Note: ⁽¹⁾ The application process of 5-axis controller is complicated and the lead time is longer than 6 months.

⁽²⁾ Paper documentation is option.

- Machine specification might be different from the catalogue if there is any specification update.

* Factory mounted only

Pull stud and applicable tools

BT40

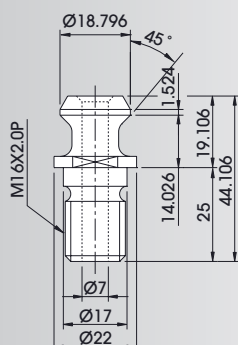

ISO (7388-B)

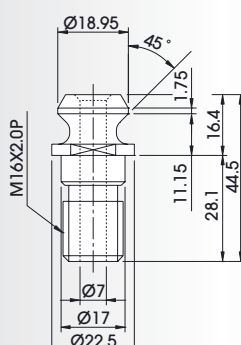

DIN (69872-A)

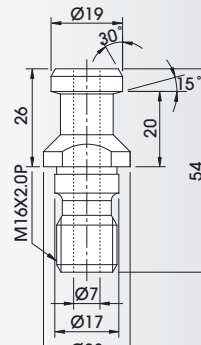

B	tool median point distance
W	tool weight
MOMENT=W*B(10.29N-m)	

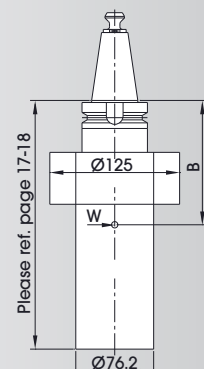

Layout

Installation dimension

MF400

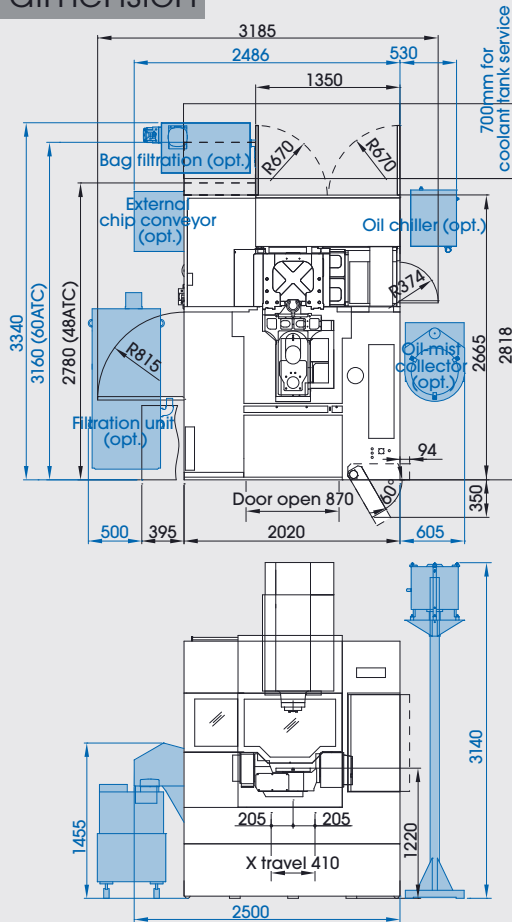

ATC	A	B
30 ~ 60	3140	510
120	3180	550

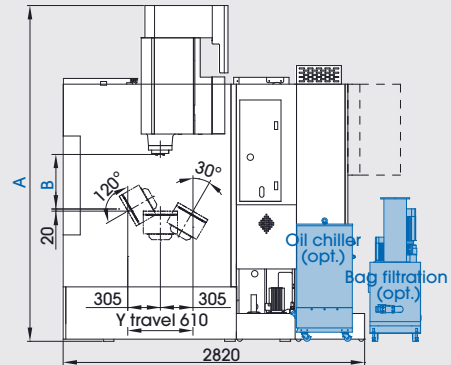

MF500

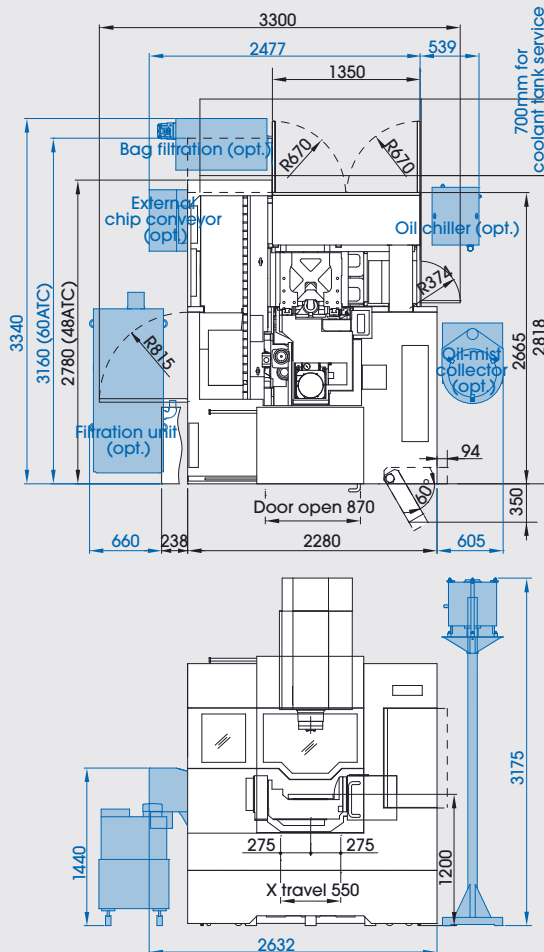

ATC	A	B
30 ~ 60	3175	610
120	3185	620

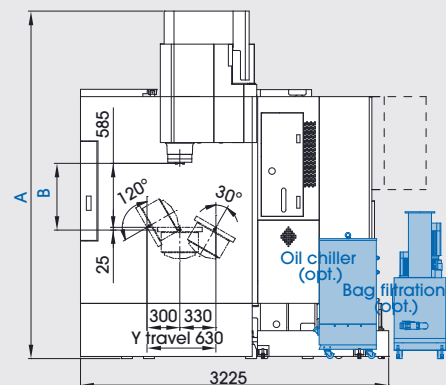

Layout

Installation dimension

MF630

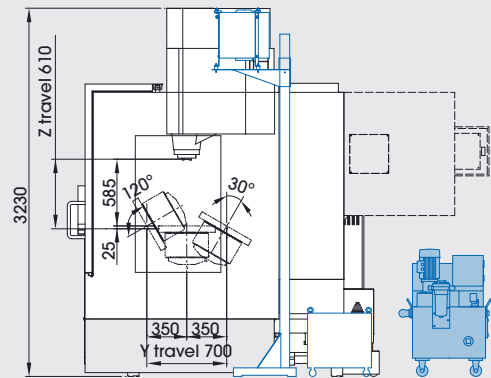
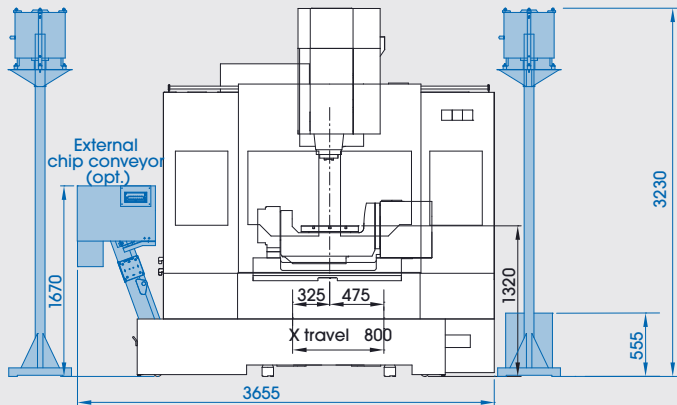
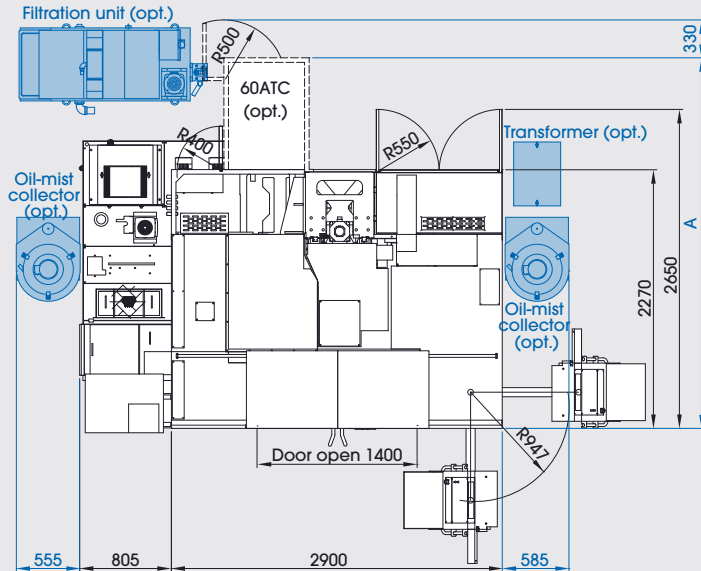

		40Taper	
A	30ATC	2,530	
	48ATC	2,870	
	60ATC	3,250	

Table dimension

MF400

MF500

MF630

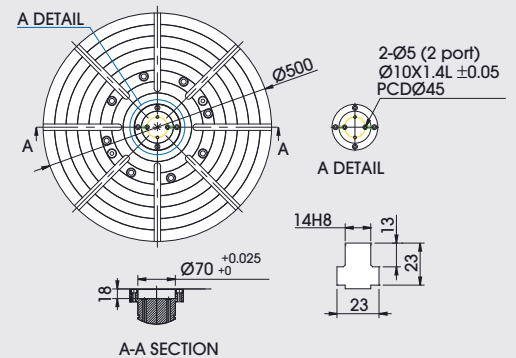
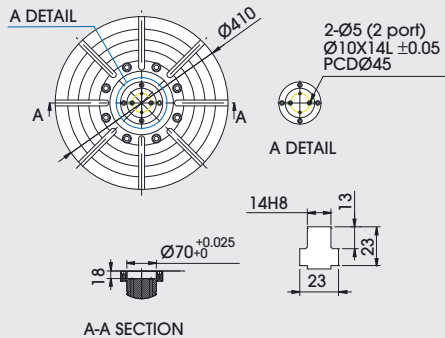
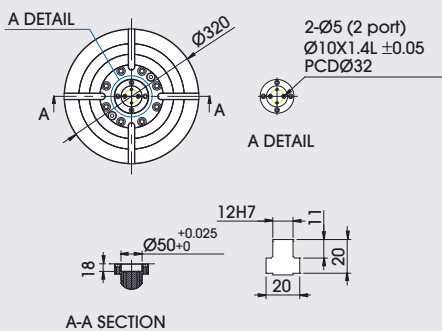

We build machines in a hybrid way

- Very classic craftsmanship combined with the most advanced modern equipment in a clean environment...

QUASER MACHINE TOOLS, INC.

Address: No. 3, Gong 6th Rd., Youshih
Industrial Park, Dajia Dist,
Taichung City 437, Taiwan
Tel: +886 4 26821277
Fax: +886 4 26822045
E-mail: sales@qmt.com.tw
Web: www.quaser.com



QUASER EUROPE TECHNIC CENTER - SWITZERLAND

Address: Unterlettenstrasse 16, CH- 9443
Widnau Switzerland
Tel: +41 71 722 43 43
Mobile phone: +41798229028
E-mail: qe@qmt.com.tw



KUNSHAN QUASER MACHINE TOOLS, INC.

Address: (B) No. 287, Kangzhuang Road,
Zhoushi Town, Kunshan City,
Jiangsu, P.R. China
Tel: 0512-82627139
Fax: 0512-82627138
E-mail: qmtc@qmt.com.tw



QUASER AMERICA MACHINE TOOLS INC.

Address: 3049 Southcross Boulevard, Rock Hill,
SC, 29730, UNITED STATES
Tel: +1 803-324-7123
Fax: +1 888-459-8175
E-mail: qa@qmt.com.tw





**QUASER MACHINE TOOLS,
INC.**

Address: No. 3, Gong 6th Rd.,
Youshih Industrial
Park, Dajja Dist,
Taichung City 437,
Taiwan
Tel: +886 4 26821277
Fax: +886 4 26822045
E-mail: sales@qmt.com.tw
Web: www.quaser.com

**QUASER EUROPE TECHNIC
CENTER - SWITZERLAND**

Address: Unterlettenstrasse
16, CH- 9443 Widnau
Switzerland
Tel: +41 71 722 43 43
Mobile phone: +41798229028
E-mail: qe@qmt.com.tw

**KUNSHAN QUASER
MACHINE TOOLS, INC.**

Address: (B) No. 287,
Kangzhuang Road,
Zhoushi Town,
Kunshan City,
Jiangsu,P.R. China
Tel: 0512-82627139
Fax: 0512-82627138
E-mail: qmtc@qmt.com.tw

**QUASER AMERICA MACHINE
TOOLS INC.**

Address: 3049 Southcross
Boulevard,Rock Hill,
SC, 29730, UNITED STATES
Tel: +1 803-324-7123
Fax: +1 888-459-8175
E-mail: qa@qmt.com.tw

Fold here for filing!