

SMART
MACHINE TOOL

NL 1500 / 2000 / 2500 / 3000

High performance CNC Turning Centers



INAXES
CNC MACHINERY

WWW.CNC-INAXES.CZ

NL Series

NL 1500, NL 2000
NL 2500, NL 3000

Chuck Size

6, 8, 10, 12 Inch

NL Series

Designed by Smart Machine Tool engineers with many years of experience, NL Series turning centers guarantee ultra-high precision, flexible, and reliable machining performance.



		NL 1500 1500M	NL 2000 2000M	NL 2000B 2000BM	NL 2500S 2500SM
Max. Machining Dia.	mm (inch)	391 (15.39) 381 (15.00)	391 (15.39) 381 (15.00)	391 (15.39) 381 (15.00)	480 (18.9) 450 (17.72)
Max. Machining Length	mm (inch)	560 (22.05) 540 (21.26)	560 (22.05) 540 (21.26)	550 (21.65) 540 (21.26)	530 (20.87) 480 (18.9)
Chuck Size	inch	6"	8"	10"	10"
Bar Capacity	mm (inch)	51 (2.01)	67 (2.64)	81 (3.19)	81 (3.19)
Spindle Speed	rpm	6,000	4,500	3,500	3,500 [4,000]
Motor (Cont./Max)	kW (HP)	11/18.5 (15/25)	15/18.5 (20/25)	15/18.5 (20/25)	15/18.5 (20/25) [22/35 (29.5/47)]
Max. Torque	N.m (ft.lbs)	157 (115.8)	336 (247.8)	447 (329.7)	1,256 (926.4) [1,336 (985.4)]
No. of Tools	EA	12	12	12	12

[] : Option

NL 1500 | 2000 | 2500 | 3000

- 45° slanted torque tube design bed and wide slideway for high rigidity machining
- Wide box guideways machined from one-piece casting promote heavy duty cutting
- High torque AC servo motor ensures fast indexing time and repeatability
- Excellence rapid traverse rate: 30m/min [1,181ipm] (Z-axis)
- High spindle power ensures powerful cutting capability
- User-friendly operation panel design for efficient machine operation
- Various peripheral equipment and options



		NL 2500 2500M	NL 2500L 2500LM	NL 3000B 3000BM	NL 3000BL 3000BLM
Max. Machining Dia.	mm (inch)	480 (18.9) 450 (17.72)	480 (18.9) 450 (17.72)	480 (18.9) 450 (17.72)	480 (18.9) 450 (17.72)
Max. Machining Length	mm (inch)	750 (29.53) 700 (27.56)	1,100 (43.31) 1,050 (41.34)	750 (29.53) 700 (27.56)	1,100 (43.31) 1,050 (41.34)
Chuck Size	inch	10"	10"	12"	12"
Bar Capacity	mm (inch)	81 (3.19)	81 (3.19)	102 (4.02)	102 (4.02)
Spindle Speed	rpm	3,500 [4,000]	3,500 [4,000]	2,800	2,800
Motor (Cont./Max)	kW (HP)	15/18.5 (20/25) [22/35 (29.5/47)]	15/18.5 (20/25) [22/35 (29.5/47)]	22/35 (29.5/47)	22/35 (29.5/47)
Max. Torque	N.m (ft.lbs)	1,256 (926.4) [1,336 (985.4)]	1,256 (926.4) [1,336 (985.4)]	1,630 (1,202.2)	1,630 (1,202.2)
No. of Tools	EA	12	12	12	12

[] : Option

Machine Structure

High Rigidity Body Structure for Heavy-duty Machining

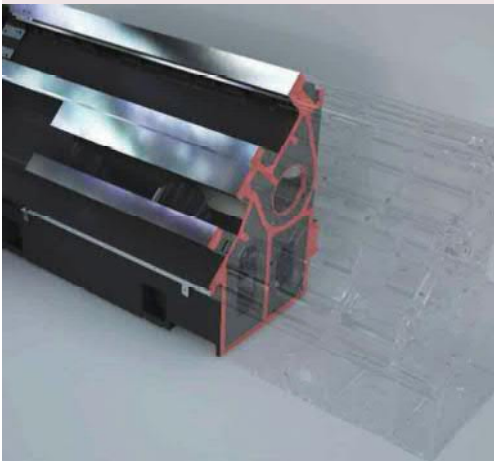
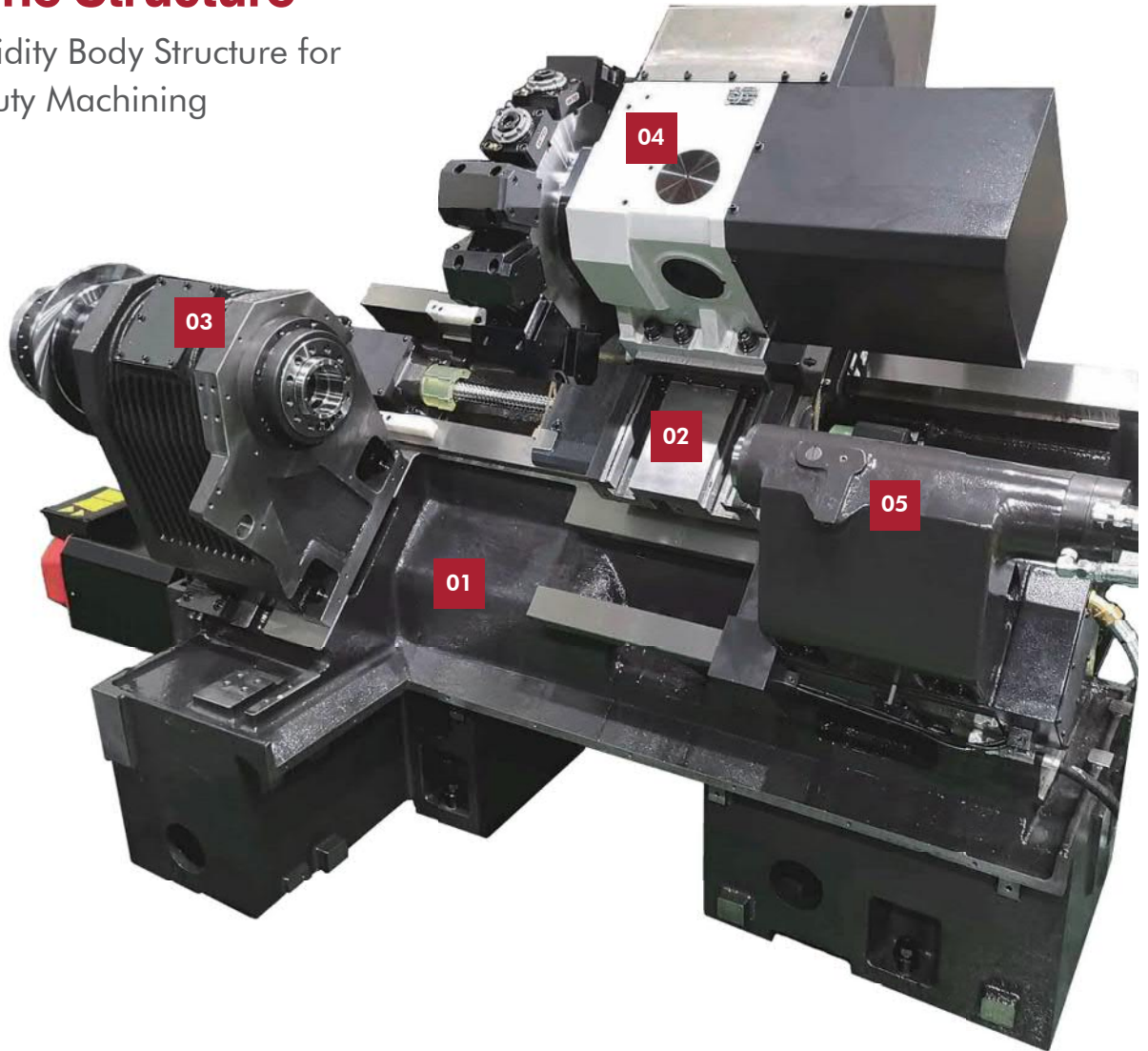

One-Piece Casting Bed

One-piece 45-degree slant bed made out of Meehanite cast iron, which has superb vibration absorption characteristics, provides rigid foundation for all machine components. Such design endures long-term machining accuracy and consistency. In addition, 45-degree slant bed design provides operators with convenient access to the workpiece and superb chip discharge.

- Precision hand scraping of contact surfaces of all slides, headstock and tailstock with the bed ensure long-lasting machining accuracy and minimal surface wears.



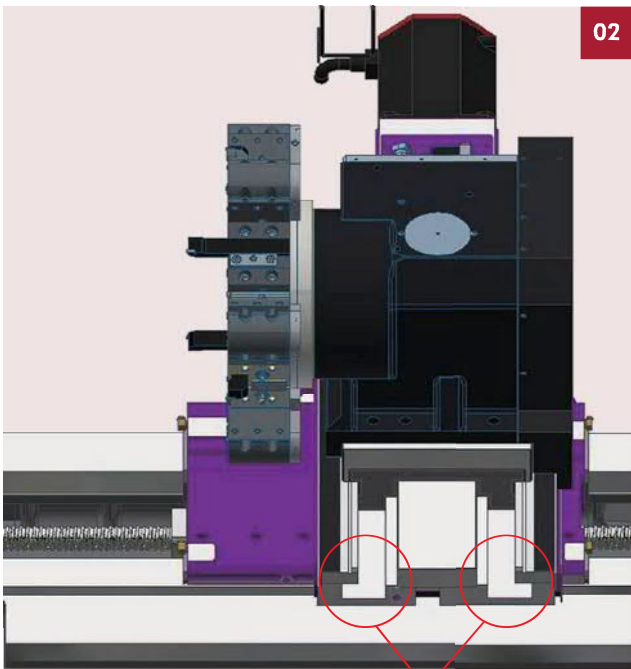

02

Z-Axis High Performance Motor

Z-axis is equipped with high performance feed motor for better travel ability.

Z-axis rapid traverse rate : 30 m/min [1,181 ipm]

Wide box guideways and Carriage

Hexahedral design and wide box guideways, machined from one piece casting, promote heavy duty machining.

Induction hardened and precision ground ways ensure accurate machining for extended period of time.

Wide carriage promotes less vibration and allows high precision machining.

Hexahedral design



Pre-tensioned Ballscrews

All axes ballscrews are pre-tensioned, heat treated and fixed by double anchors on both ends, providing ultimate rigidity and minimal thermal growth.

12-Station Turret

Large diameter 3-piece Curvic coupling for excellence rigidity and extended tool life.

High torque AC servo motor driven ensure fast indexing time, excellence position and repeatability.

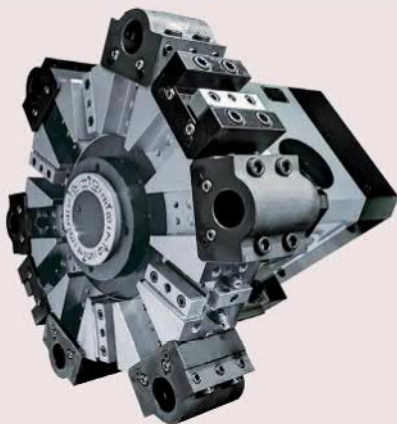

04

Programmable Tailstock Body & Quill

Wide-spaced guideways and heavy-duty tailstock body design ensure machining rigidity, and built in spindle quill design ensures higher rigidity.

NL 1500/2000

- Quill Type : **MT#4(Live)**
- Quill Dia. : **Ø80mm**
- Quill Travel : **80mm**

NL 2500/3000

- Quill Type : **MT#4(Built-in)**
- Quill Dia. : **Ø110mm**
- Quill Travel : **100mm**



03

Main Spindle

Double row cylindrical roller bearings in the front and back, coupled with angular thrust bearing, ensure high rigidity for heavy cutting and excellent surface finishes.

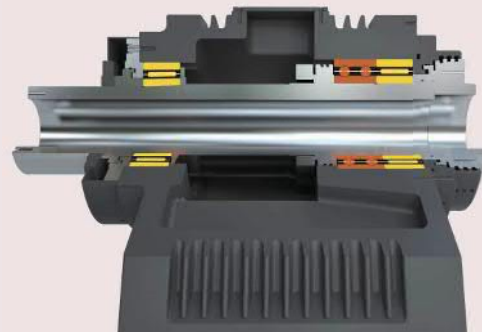

Main Spindle

High Accuracy & Performance CNC Turning Center



Main Spindle

Heavy-duty headstock machined from one-piece casting. Reinforced with radiator fan-like pin tube rip design dissipates heat generated by axis movements, maintaining minimal thermal expansion.

		NL 1500	NL 2000	NL 2000B	NL 2500	NL 3000
Chuck size	inch	6"	8"	10"	10"	12"
Spindle Nose	ASA	A2-5	A2-6	A2-8	A2-8	A2-11
Max Speed	rpm	6,000	4,500	3,500	3,500 [4,000]	2,800
Thru Hole Dia.	mm(inch)	Ø61(2.4)	Ø76(2.99)	Ø91(3.58)	Ø91(3.58)	Ø115(4.53)
Draw tube I.D.	mm(inch)	Ø52(2.05)	Ø68(2.68)	Ø82(3.23)	Ø82(3.23)	Ø103(4.06)

[] : Option

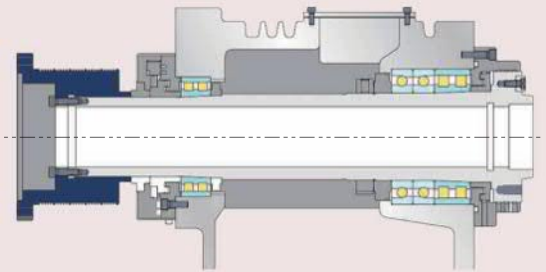

- Spindle pulley system is equipped with powerful and reliable Fanuc AC motor to ensure excellence heavy-duty cutting capability.
- PK type pulley belt is used to achieve low vibration, low noise and good surface roughness cutting result even at high speed.

NL 1500/2000



NL 2500/3000
(2-speed gearbox)



NL 1500 : 6,000 rpm

Max. Output

18.5 kW [25 HP]

Max. Torque

157 N.m [116 lbf.ft]

NL 2000 : 4,500 rpm

Max. Output

18.5 kW [25 HP]

Max. Torque

336 N.m [248 lbf.ft]

NL 2000B : 3,500 rpm

Max. Output

18.5 kW [25 HP]

Max. Torque

447 N.m [330 lbf.ft]

NL 2500 (Standard) : 3,500 rpm

Max. Output

18.5 kW [25 HP]

Max. Torque

1,256 N.m [926 lbf.ft]

NL 2500 (Option) : 4,000 rpm

Max. Output

35 kW [47 HP]

Max. Torque

1,336 N.m [985 lbf.ft]

NL 3000 : 2,800 rpm

Max. Output

35 kW [47 HP]

Max. Torque

1,630 N.m [1,202 lbf.ft]

Spindle Torque Diagram

NL 1500

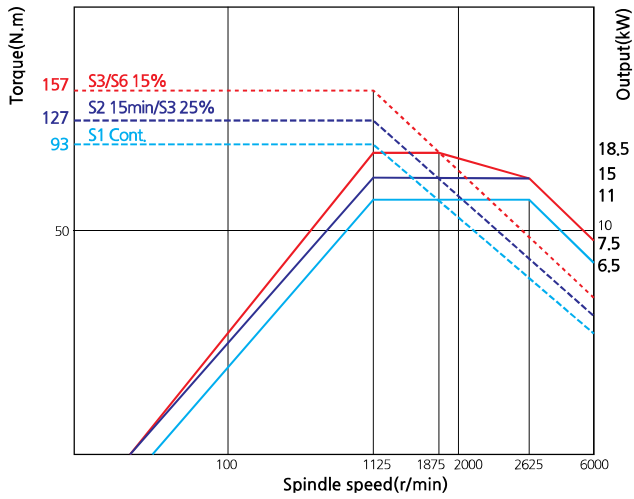

NL 2000

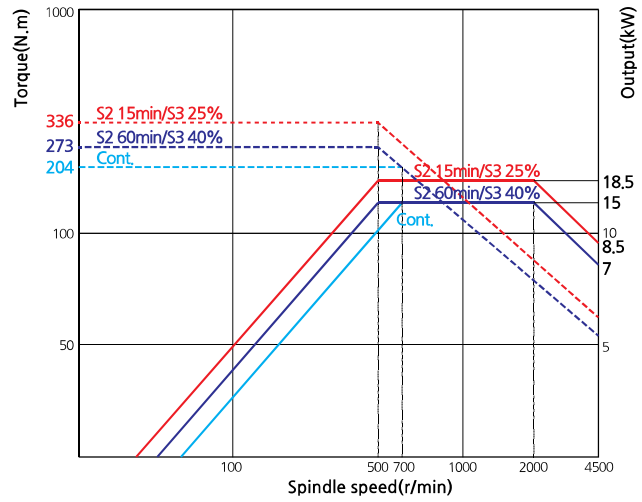

NL 2000B

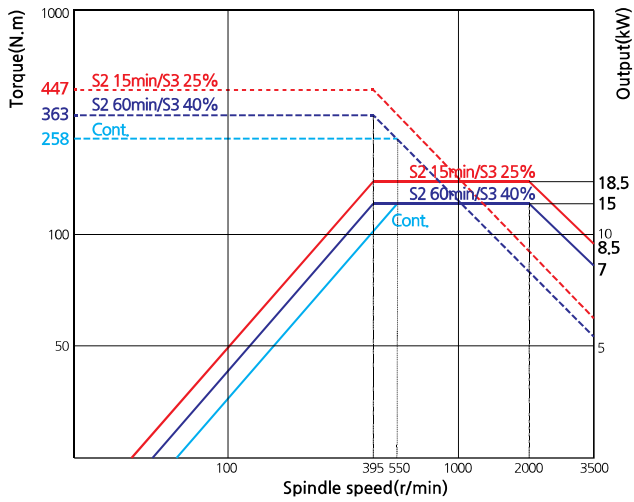

NL 2500 Std.

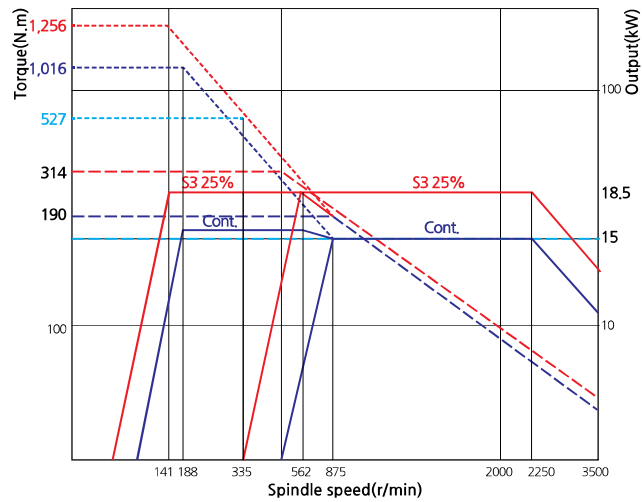

NL 3000

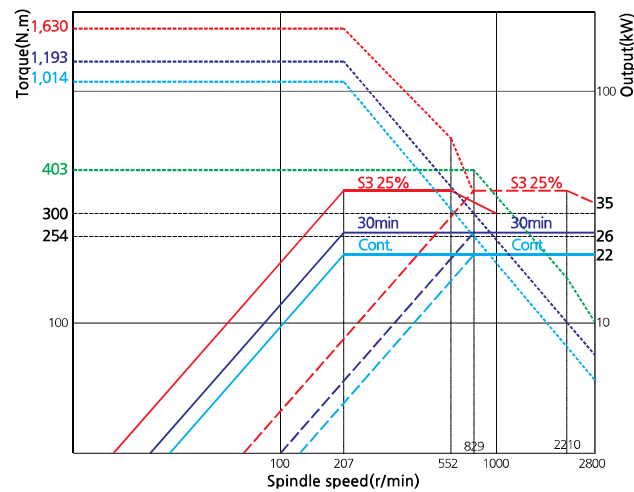

NL 2500 Opt.

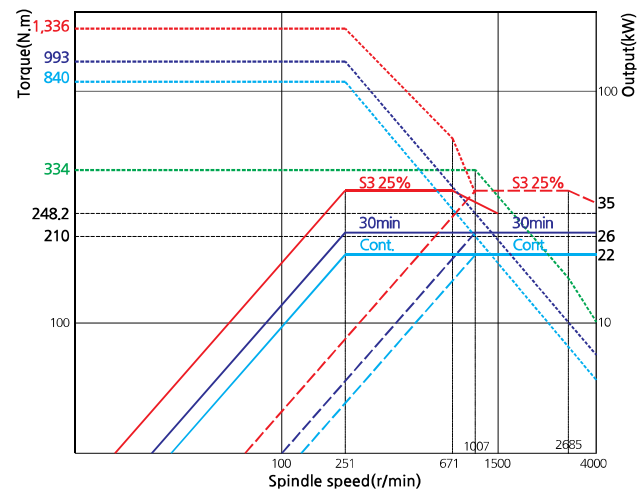

Turret

Finest performance and high precision turret

Standard Turret

Heavy-duty turret driven by high torque AC servo motor for rapid rotation and repeatability. The turret design features large diameter Curvic coupling ensure accurate positioning and strong clamping power.

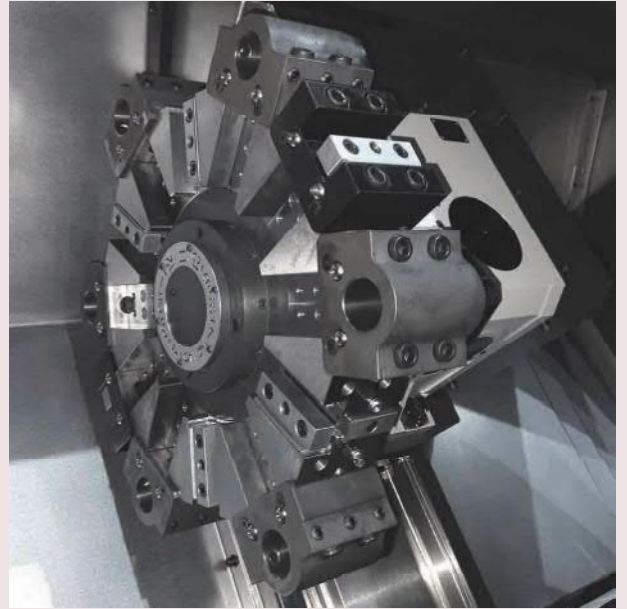
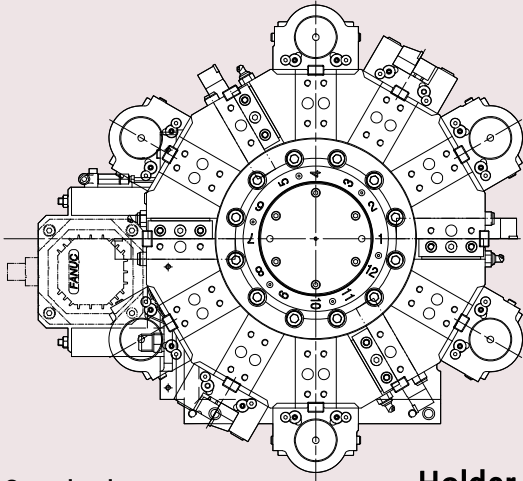

Standard turret

- No. of Tools : 12 EA
- Indexing Time : 0.15 sec (NL 1500/2000)
- Indexing Time : 0.2 sec (NL 2500/3000)

Holder



Boring holder

- NL 1500/2000 : $\varnothing 40$ (1.5")
- NL 2000B/2500/3000BL : $\varnothing 50$ (2")



Bite holder

- $\square 25$ (1")

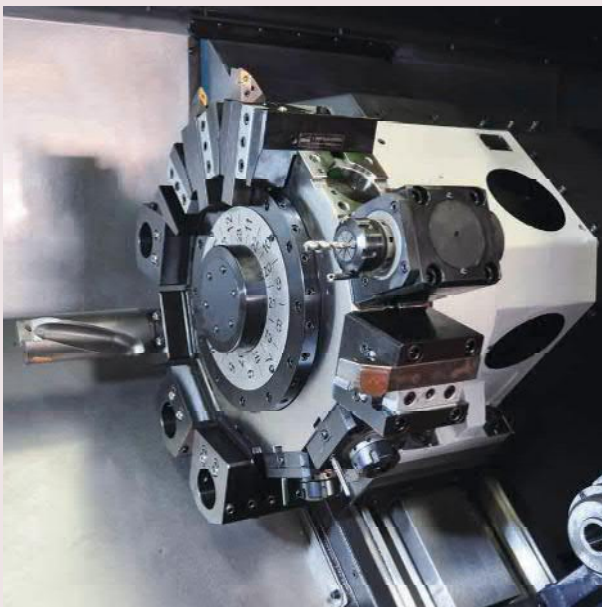

BMT Mill Turret

BMT turret is equipped with 2 separated motors for indexing and milling which improving machining performance and reducing processing time of workpiece.

Mill Tool Holder

Tool holder is mounted to BMT turret by 4 screws ensures stability, rigidity and heavy-duty machining operations.

Straight mill holder



Angular mill holder



■ Mill Tool Torque Diagram

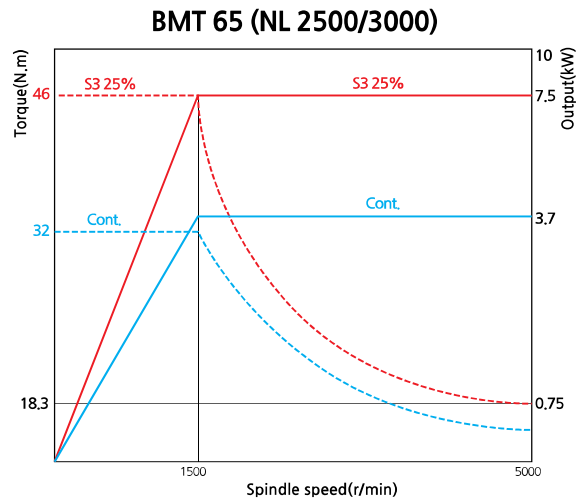
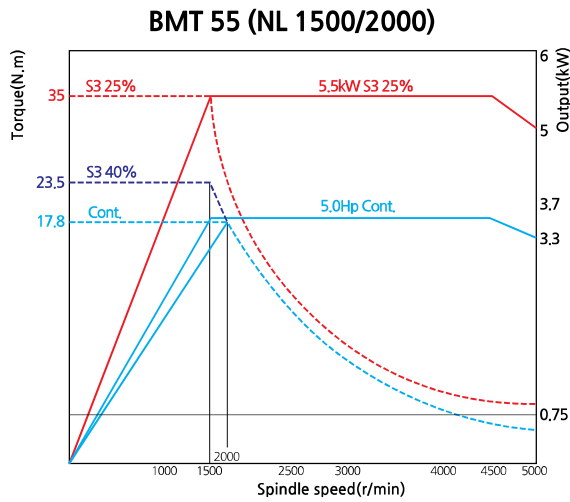

⬡ Tailstock

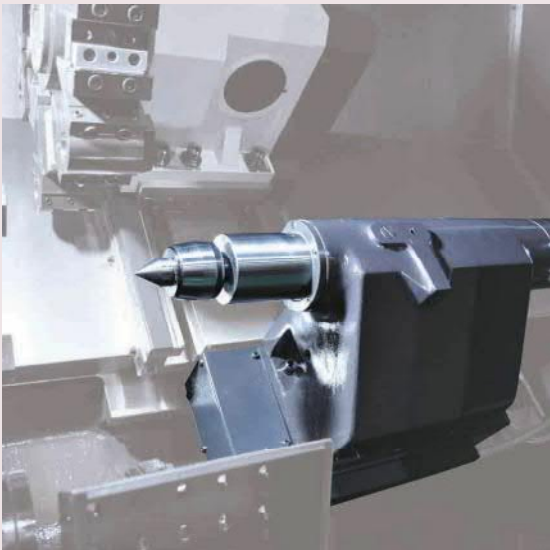

Programmable tailstock body & quill is provided as standard equipment for NL series, make easier to adjust tailstock position and minimize setup time.

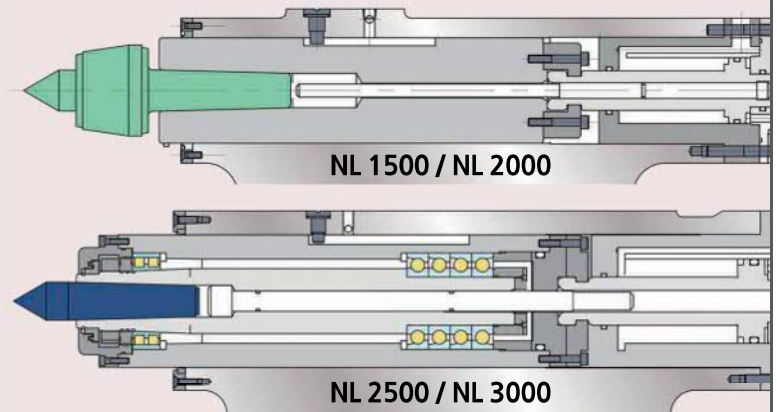

		NL 1500	NL 2000	NL 2500	NL 3000
Quill dia.	mm(inch)	Ø80		Ø110	
Quill travel	mm(inch)	80(3.15)		100(3.94)	
Taper	-	MT4 live		MT4 (built-in)	
Hydraulic clamp	kgf(lbf)	3,800(8,377)		11,000(24,251)	
Hydraulic quill	kgf(lbf)	515(1,135)		1,008(2,222)	

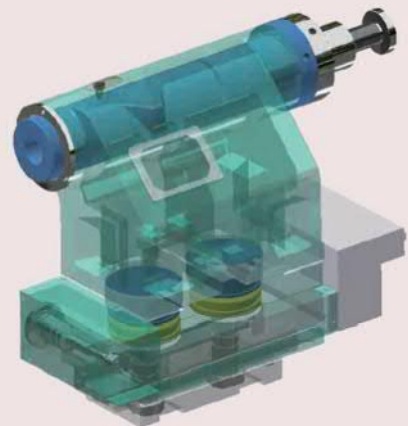

Ballscrew

Ultimate rigidity ballscrew

Pre-Tensioned and Double Anchored Ballscrews

Both ends of X-axis and Z-axis are fixed and preloaded with P4 high precision Angular contact ball bearing ensure precise and smooth rotation.

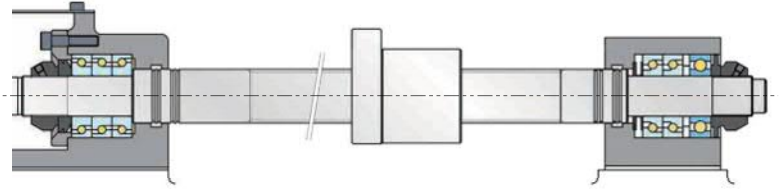

Z-Axis

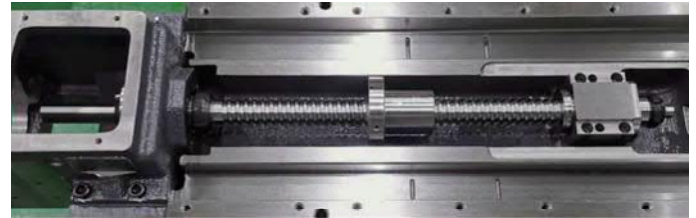

X-Axis

Machining Area

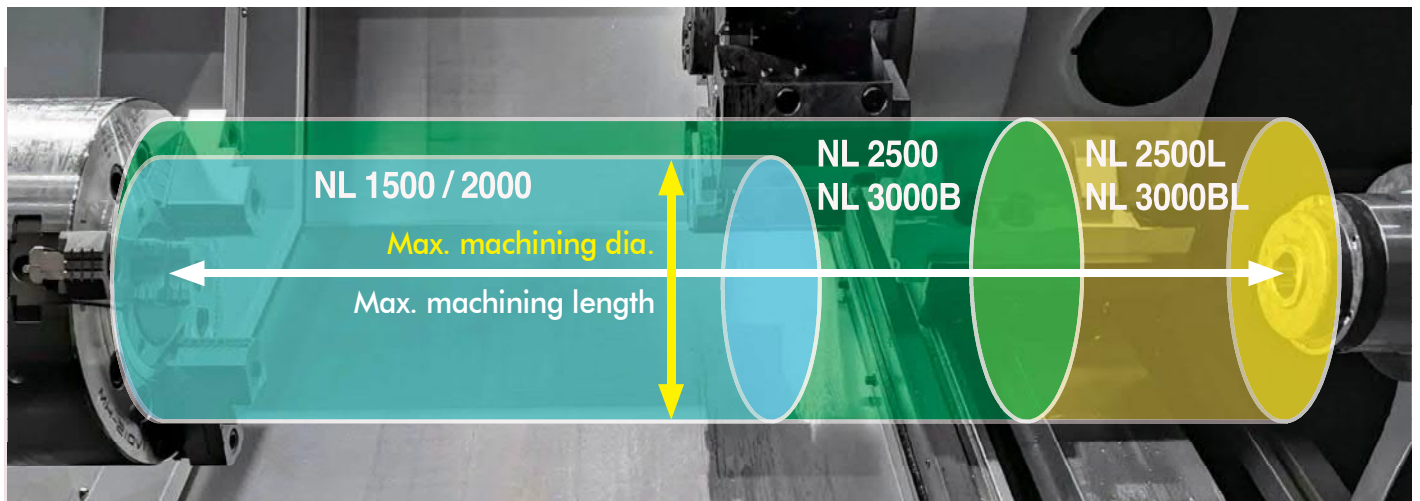

Model	Max. machining dia.	Max. machining length	Bar capacity
NL 1500	Ø391 (15.39")	560 (22.05")	51 (2.01")
NL 1500M	Ø381 (15.00")	540 (21.26")	
NL 2000	Ø391 (15.39")	560 (22.05")	67 (2.64")
NL 2000M	Ø381 (15.00")	540 (21.26")	
NL 2000B	Ø391 (15.39")	550 (21.65")	81 (3.19")
NL 2000BM	Ø381 (15.00")	540 (21.26")	
NL 2500S	Ø480 (18.90")	530 (20.87")	81 (3.19")
NL 2500SM	Ø450 (17.72")	480 (18.90")	
NL 2500	Ø480 (18.90")	750 (29.53")	
NL 2500M	Ø450 (17.72")	700 (27.56")	
NL 2500L	Ø480 (18.90")	1,100 (43.31")	
NL 2500LM	Ø450 (17.72")	1,050 (41.34")	
NL 3000B	Ø480 (18.90")	750 (29.53")	102 (4.02")
NL 3000BM	Ø450 (17.72")	700 (27.56")	
NL 3000BL	Ø480 (18.90")	1,100 (43.31")	
NL 3000BLM	Ø450 (17.72")	1,050 (41.34")	

Cutting Performance

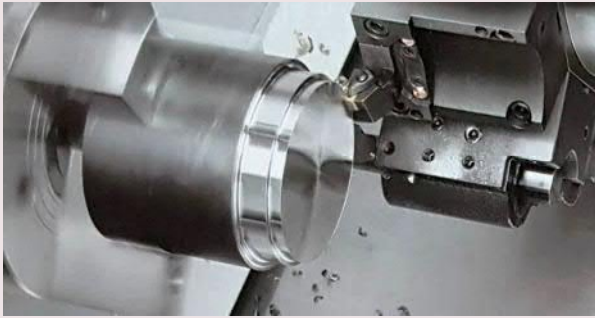

Heavy-duty cutting <O.D.>

Machine type	NL 2500
Material <JIS>	S45C
Spindle speed	367 min ⁻¹
Depth of cut	8 mm (0.312 inch)
Cutting speed	152 m/min (500 fpm)
Feedrate	0.5 mm/rev (0.020 ipr)

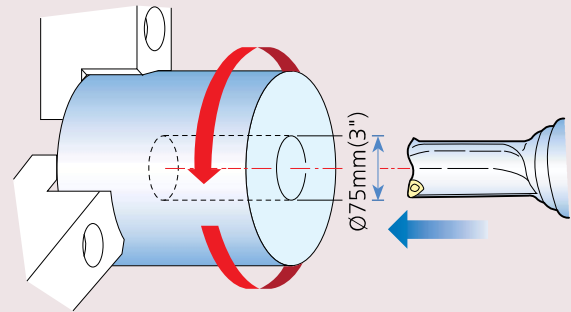

Insert Drill

Machine type	NL 2500
Material <JIS>	S45C
Spindle speed	417 min ⁻¹
Drill diameter	75 mm (3 inch)
Feedrate	0.15 mm/rev (0.006 ipr)

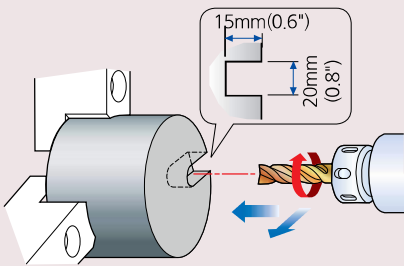

End mill <Ø20mm(0.8") High-speed steel>

Machine type	NL 2500
Material <JIS>	S45C
Rotary tool spindle speed	320 min ⁻¹
Depth of cut	15 mm (0.6 inch)
Cutting speed	20 m/min (65.6 fpm)
Feedrate	65 mm/min (2.5 ipm)

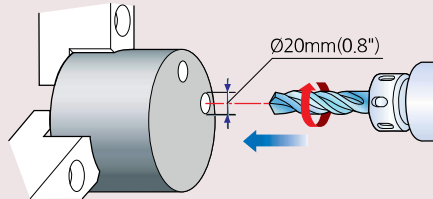

Drill <Ø20mm(0.8") High-speed steel>

Machine type	NL 2500
Material <JIS>	S45C
Rotary tool spindle speed	391 min ⁻¹
Cutting speed	25 m/min (82.0 fpm)
Feedrate	105 mm/min (4.1 ipm)

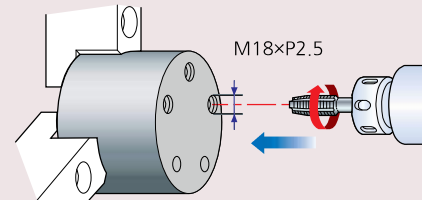

Tap <M18xP2.5>

Machine type	NL 2500
Material <JIS>	S45C
Rotary tool spindle speed	160 min ⁻¹
Cutting speed	10 m/min (32.8 fpm)
Feedrate	400 mm/min (15.7 ipm)

Roundness (Turning)

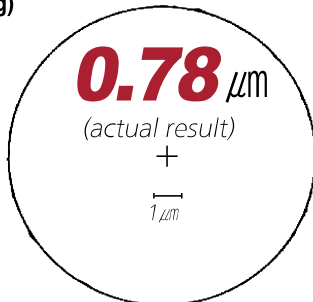

Machine type	Unit	NL 2500
Material	-	Brass (Ø80mm x L60mm)
Tool	-	Diamond tool
Cutting depth	mm(inch)	0.1(0.004)
Feedrate	mm/rev(ipr)	0.05(0.002)
Nose radius	mm(inch)	0.5(0.02)

Surface Roughness (Turning)

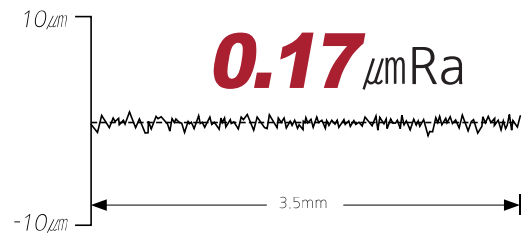

SMART Operation Features

Smart NL Series Turning Centers take operator convenience to the next level, offering key optional accessories as standard features of the machines.

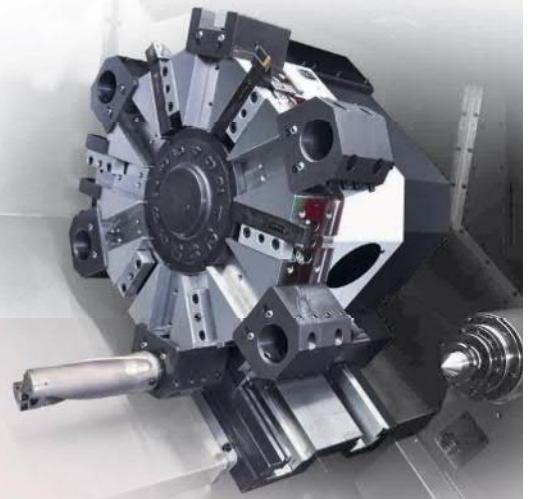

BZi Sensor **Std.**

SMART provides BZi sensor as standard equipment, instead of position coder, for all models of NL series.

Use of BZi sensor helps reduce after sale service cost as BZi sensor does not require maintenance, unlike position coder which need regular service maintenance.

Operator-Friendly Keyboard Layout **Std.**



- 10.4" color monitor
- Semi-permanent A/S LED lamping
- Waterproof button
- Big button size
- Replaceable button cap
- Light indicator at 100% driving status

Operator-friendly keyboard design for efficient machine operation, with protected sealed buttons to prevent letters and signs from wearing off. Operator panel swivels up to 90 degrees, providing operators with easy access to the panel while working on the machine.

Metered Lubrication System **Std.**

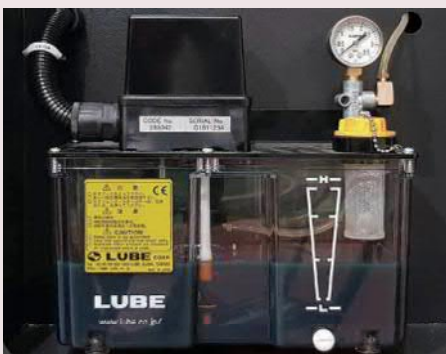

Automatic lubrication dispenser reliably dispenses exact amount of lubrication, only when axes is in operation. In the event of lubrication line failure, the system generates a warning message on CRT and stops the machine for operation safety.

High Pressure Coolant Pump **Std.** / Oil Skimmer **Opt.**



Standard high pressure coolant pump sufficiently cools off the heat generated while cutting, ensuring precision machining and extended tool life, while Oil Skimmer effectively removes oil from coolant.



Belt type oil skimmer



Easy plug-in / remove cable

Manual Guide i **Opt.**



MGI enables operators to program and simulate part programs using a conversational programming without actually running the machine.

Programmable Tailstock and Quill **Std.**

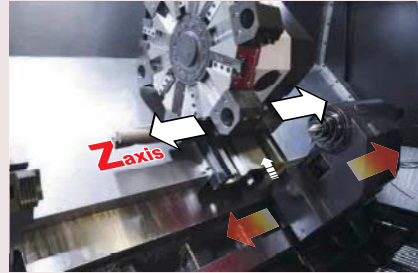

Programmable tailstock and quill make the set-up easier and faster.

Tool Presetter **Opt.**



Tool presetter reduces set-up time by minimizing the need for manual skin cuts, measurement, and entering of tool offsets.

Chip Conveyor **Opt.**

Equipped with wide hinged belt, worm gear reducer and torque limiter ensure stable movement and efficiently disposes of chips.

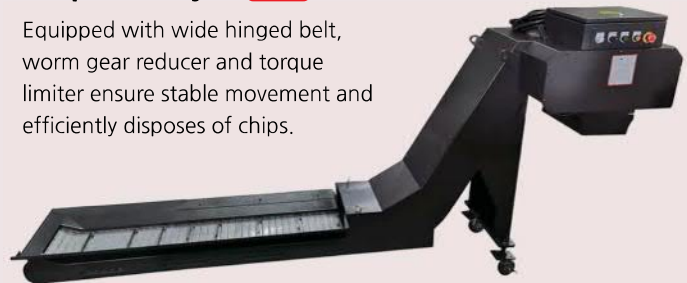

Highly Reliable Electrical Components **Std.**

Brake, power and relay circuits are integrated into one board system to minimize electrical system failure and easily to maintenance and service.



Service Oriented Sheet Metals Design **Std.**

Sheet metals are designed for easy access to the parts/units when service is needed.

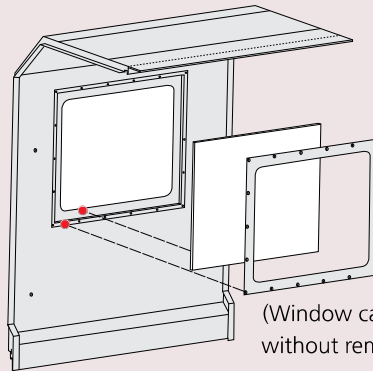

(Window can be replaced without removing the door)

Features

Part Catcher Opt.

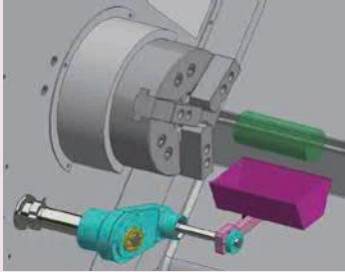

Automatically catches completed parts after cut-off.

CE Approved Foot Switch Std. / Air Gun&Coolant Gun Opt.

Connection-ready module design to easily add or remove accessories.



Dual Chuck Opt.



Dual chuck system helps improve machining stability for long workpiece by fix the workpiece at two positions.

Steady Rest Opt.

Steady rest supports turning long workpiece and prevent workpiece from trembling.



Model	SMW-AUTOBLOK	
	SLU-X2	SLU-X3/3.1
NL 1500	○	×
NL 2000	○	×
NL 2500	×	○
NL 3000	×	○

Re-Machining Function Opt.

This function allows user to easily repair damaged part.

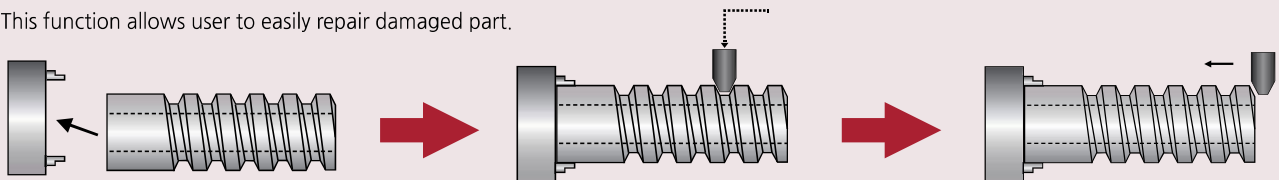

Step 1 : Load the damaged part into the machine.

Step 2 : Manually positioning the tool into the machined thread with the spindle stopped and then registering the position with the CNC.

Step 3 : Retract the tool, start the spindle and run the part program to re-machined the thread.

Arbitrary Speed Threading Opt.

Arbitrary speed threading ensures cutting tool remains coordinated with spindle speed at all time during threading. It allows user to adjust spindle speed during threading without damaging the part.

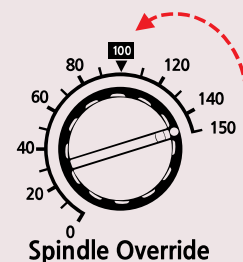
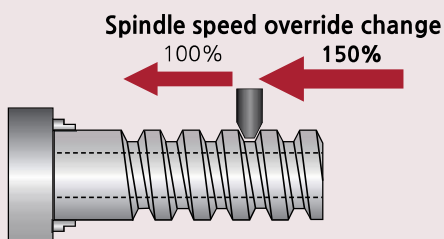

Standard & Option Specifications

● : Standard features ○ : Option X : Not applicable

		NL 1500		NL 2000				NL 2500						NL 3000			
		-	M	-	M	B	BM	-	M	S	SM	L	LM	B	BM	BL	BLM
Spindle and Chucking																	
Chuck size	6 inch	●	●	X	X	X	X	X	X	X	X	X	X	X	X	X	X
	8 inch	X	X	●	●	X	X	X	X	X	X	X	X	X	X	X	X
	10 inch	X	X	X	X	●	●	●	●	●	●	●	●	X	X	X	X
	12 inch	X	X	X	X	X	X	○	○	○	○	○	○	●	●	●	●
Dual pressure chucking		○	○	○	○	○	○	○	○	○	○	○	○	○	○	○	○
Chuck pressure switch		○	○	○	○	○	○	○	○	○	○	○	○	○	○	○	○
Chuck clamp foot switch		●	●	●	●	●	●	●	●	●	●	●	●	●	●	●	●
Chuck clamp confirmation		●	●	●	●	●	●	●	●	●	●	●	●	●	●	●	●
Dual chuck		X	X	X	X	X	X	X	X	X	X	X	X	○	○	○	○
2 step gearbox		X	X	X	X	X	X	●	●	●	●	●	●	●	●	●	●
Jaw																	
Hydraulic hollow chuck		●	●	●	●	●	●	●	●	●	●	●	●	●	●	●	●
Soft jaw	3 set	●	●	●	●	●	●	●	●	●	●	●	●	●	●	●	●
Hard jaw	1 set	●	●	●	●	●	●	●	●	●	●	●	●	●	●	●	●
Special chuck		○	○	○	○	○	○	○	○	○	○	○	○	○	○	○	○
Steady Rest																	
SLU-X 2	Ø8~Ø101 mm (0.31~3.98 inch)	○	○	○	○	○	○	X	X	X	X	X	X	X	X	X	X
SLU-X 3	Ø12~Ø152 mm (0.47~5.98 inch)	X	X	X	X	X	X	○	○	○	○	○	○	○	○	○	○
SLU-X 3.1	Ø20~Ø165 mm (0.79~6.5 inch)	X	X	X	X	X	X	○	○	○	○	○	○	○	○	○	○
Tailstock																	
Programmable tailstock		●	●	●	●	●	●	●	●	●	●	●	●	●	●	●	●
Tailstock taper	MT#4	●	●	●	●	●	●	●	●	●	●	●	●	●	●	●	●
Built-in live center		○	○	○	○	○	○	●	●	●	●	●	●	●	●	●	●
Tailstock in-out foot switch		●	●	●	●	●	●	●	●	●	●	●	●	●	●	●	●
Coolant																	
High pressure coolant pump	4.5 bar (65 psi)	●	●	●	●	●	●	X	X	X	X	X	X	X	X	X	X
	10 bar (140 psi)	○	○	○	○	○	○	●	●	●	●	●	●	●	●	●	●
Oil skimmer		○	○	○	○	○	○	○	○	○	○	○	○	○	○	○	○
Coolant chiller		○	○	○	○	○	○	○	○	○	○	○	○	○	○	○	○
Chuck coolant		○	○	○	○	○	○	○	○	○	○	○	○	○	○	○	○
Shower coolant		○	○	○	○	○	○	○	○	○	○	○	○	○	○	○	○
Coolant gun		○	○	○	○	○	○	○	○	○	○	○	○	○	○	○	○
Chip Disposal																	
Side chip conveyor		○	○	○	○	○	○	○	○	○	○	○	○	○	○	○	○
Rear chip conveyor		○	○	○	○	○	○	○	○	○	○	X	X	○	○	X	X
Chip bucket		○	○	○	○	○	○	○	○	○	○	○	○	○	○	○	○
Air gun		○	○	○	○	○	○	○	○	○	○	○	○	○	○	○	○
Air blower system		○	○	○	○	○	○	○	○	○	○	○	○	○	○	○	○
Measurement & Automatic Operation																	
Tool presetter		○	○	○	○	○	○	○	○	○	○	○	○	○	○	○	○
Auto door		○	○	○	○	○	○	○	○	○	○	○	○	○	○	○	○
Parts catcher		○	○	○	○	○	○	○	○	○	○	○	○	X	X	X	X
Others																	
Operation status light tower		●	●	●	●	●	●	●	●	●	●	●	●	●	●	●	●
Work light (LED lamp)		●	●	●	●	●	●	●	●	●	●	●	●	●	●	●	●
Manual and part list		●	●	●	●	●	●	●	●	●	●	●	●	●	●	●	●
Door interlock		●	●	●	●	●	●	●	●	●	●	●	●	●	●	●	●
Tool/work box		●	●	●	●	●	●	●	●	●	●	●	●	●	●	●	●
Leveling blocks		●	●	●	●	●	●	●	●	●	●	●	●	●	●	●	●
Manual guide i		○	○	○	○	○	○	○	○	○	○	○	○	○	○	○	○

Machine Dimensions

Unit : mm (inch)

Top view

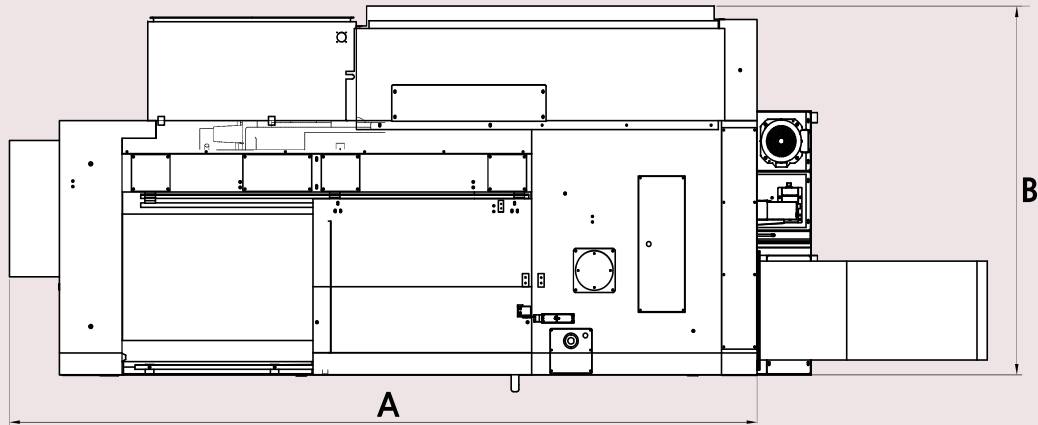

Front view

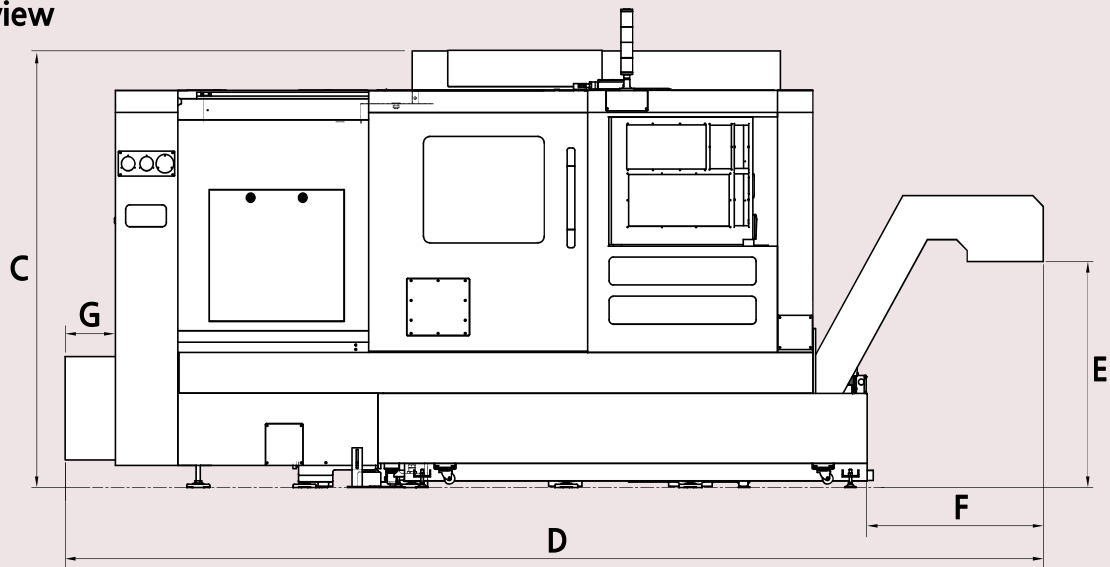

Model	A (Length)	B (Width)	C (Height)	D (Length with side chip conveyor)	E (Chip conveyor height)	F (Side chip conveyor)	G (Width of motor cover)
NL 1500/M	2,743 (107.99)	1,551 (61.06)	1,902 (74.88)	3,776 (148.66)	975 (38.89)	783 (30.83)	128 (5.03)
NL 2000/M NL 2000B/BM	2,793 (109.96)			3,826 (150.63)			178 (7)
NL 2500S/SM	3,225(126.97)	1,678 (66.06)	1,985 (78.15)	4,430(174.41)	1,026 (40.39)	845 (33.27)	380(14.96)
NL 2500/M	3,584(141.10)			4,690(184.65)			240 (9.45)
NL 2500L/LM	3,985(156.89)			4,996 (196.69)			
NL 3000B/BM	3,584(141.10)			4,690(184.65)			
NL 3000BL/BLM	3,985(156.89)			4,996 (196.69)			

Interference

Unit : mm (inch)

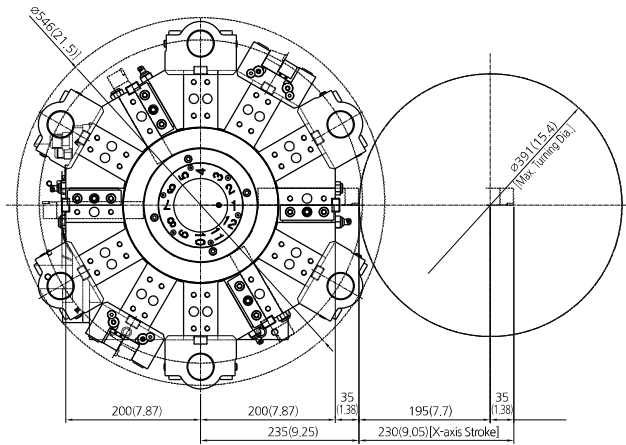

**NL 1500/2000/2000B
(12 Station Std. Turret)**

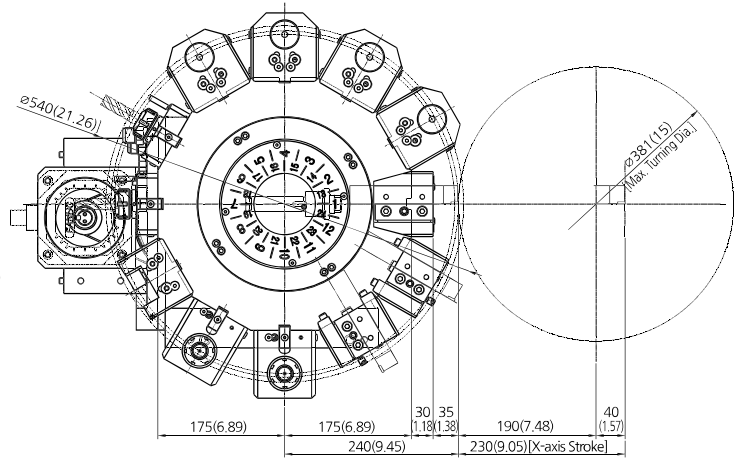

**NL 1500M/2000M/2000BM
(BMT55 12 Station
[24 position] Mill Turret)**

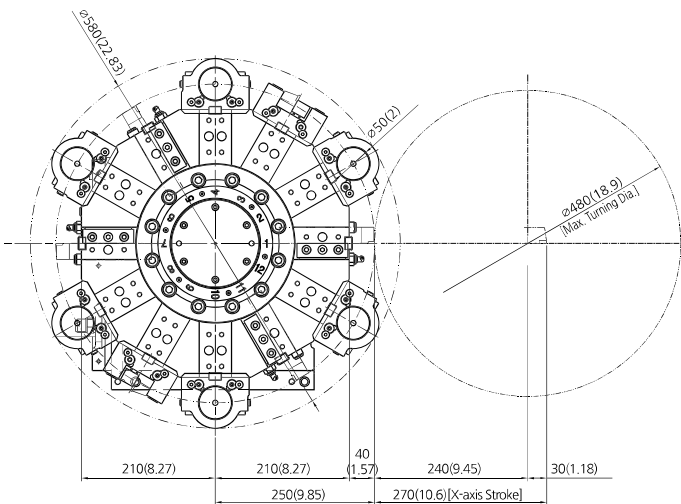

**NL 2500/3000B
(12 Station Std. Turret)**

**NL 2500M/3000BM
(BMT65 12 Station
[24 Position] Mill Turret)**

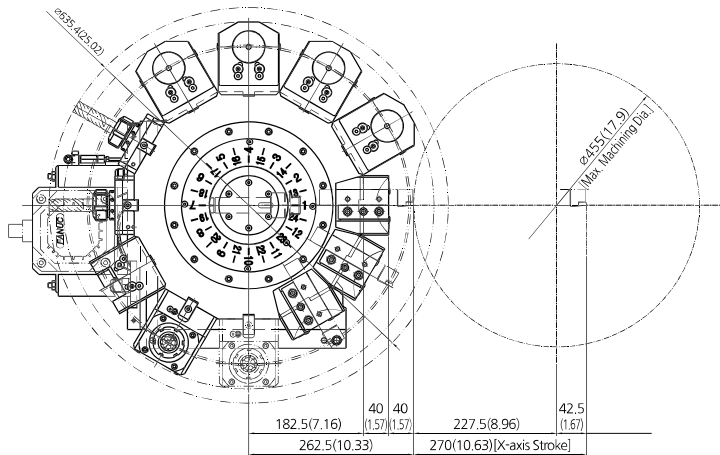

Tooling System

Standard Turret (12 Station)

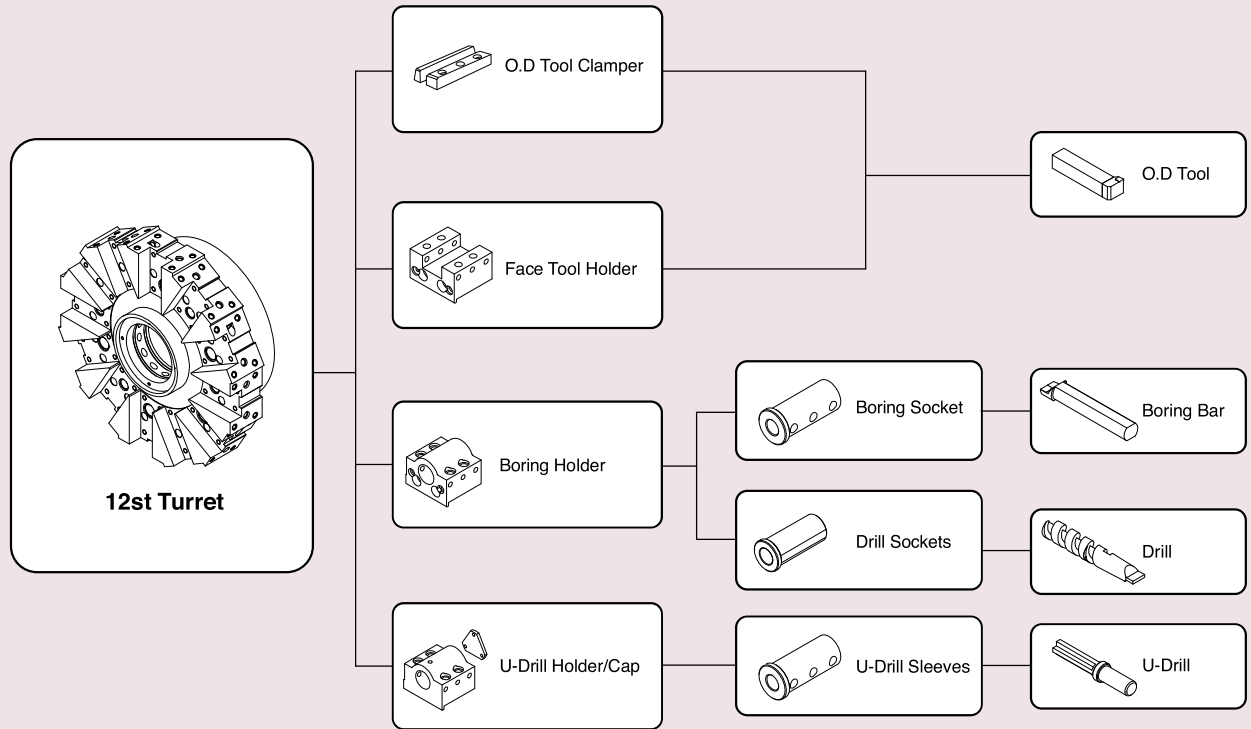

Standard Tooling Parts

Unit : mm(inch)

ITEM/ MODEL		NL 1500	NL 2000	NL 2000B	NL 2500	NL 3000B
Turning Holder	O.D Holder	-	-	-	-	-
	Facing Holder	2	2	2	2	2
Boring Holder	I.D Holder	5	5	5	5	5
	U-Drill Holder/Cap	-	1	1	1	1
Driven Holder	Axial Milling Holder	-	-	-	-	-
	Radial Milling Holder	-	-	-	-	-
Socket	Boring	Ø10(3/8")	1	1	1	1
		Ø12(1/2")	1	1	1	1
		Ø16(5/8")	1	1	1	1
		Ø20(3/4")	2	2	2	2
		Ø25(1")	2	2	2	2
		Ø32(1 1/4")	2	2	2	2
		Ø40(1 1/2")	-	-	2	2
		Ø50(2")	-	-	-	-
	Ø60(2 1/2")	-	-	-	-	
	Drill	MT2	1	1	-	-
MT3		1	1	1	1	
MT4		-	-	1	1	
MT5		-	-	-	-	

BMT Turret (12 Station)

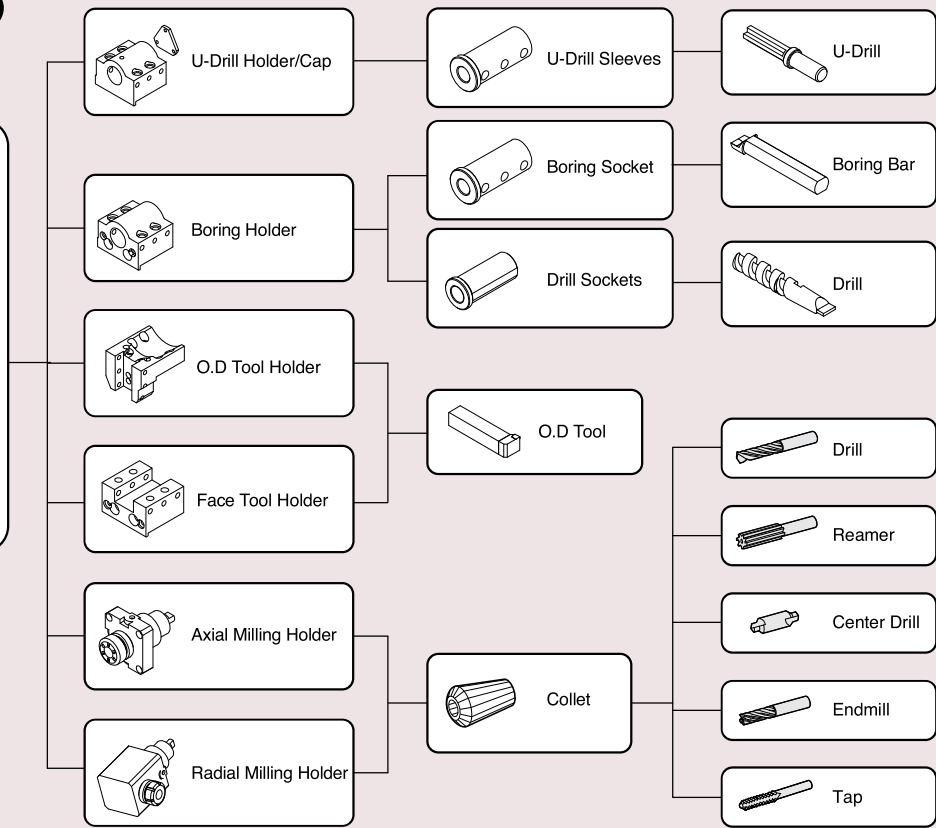
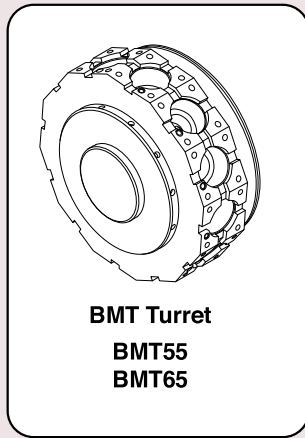

Standard Tooling Parts

Unit : mm(inch)

ITEM/ MODEL		NL 1500M	NL 2000M	NL 2000BM	NL 2500M	NL 3000BM	
Turning Holder	O.D Holder	3	3	3	3	3	
	Facing Holder	1	1	1	1	1	
Boring Holder	I.D Holder	3	3	3	3	3	
	U-Drill Holder/Cap	-	1	1	1	1	
Driven Holder	Axial Milling Holder	1	1	1	1	1	
	Radial Milling Holder	1	1	1	1	1	
Socket	Boring	Ø10(3/8")	1	1	1	1	
		Ø12(1/2")	1	1	1	1	
		Ø16(5/8")	1	1	1	1	
		Ø20(3/4")	2	2	2	2	
		Ø25(1")	2	2	2	2	
		Ø32(1 1/4")	2	2	2	2	
		Ø40(1 1/2")	-	-	-	2	2
		Ø50(2")	-	-	-	-	-
	Ø60(2 1/2")	-	-	-	-	-	
	Drill	MT2	1	1	1	-	-
		MT3	1	1	1	1	1
		MT4	-	-	-	1	1
MT5		-	-	-	-	-	

Work Range

Unit : mm(inch)

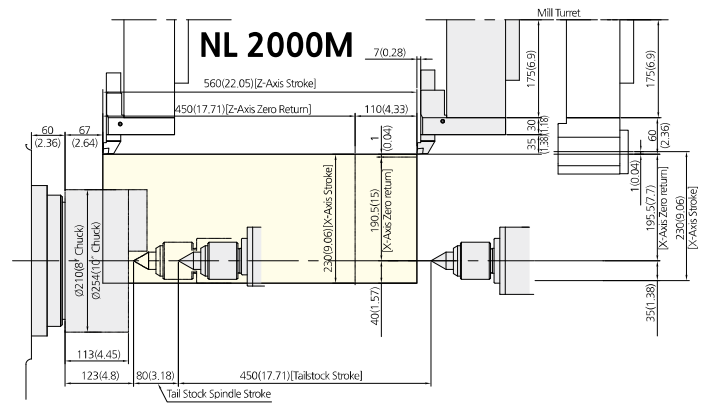
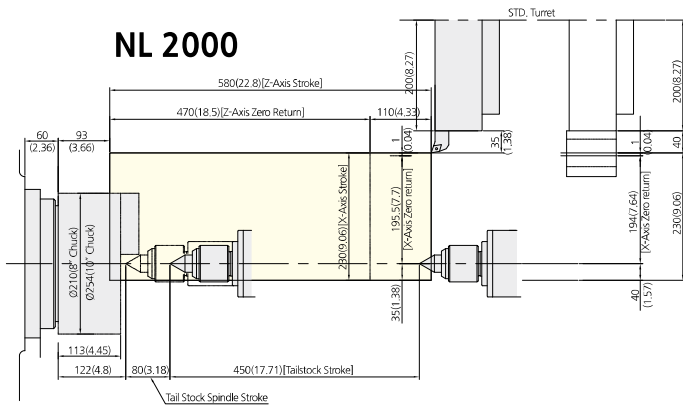
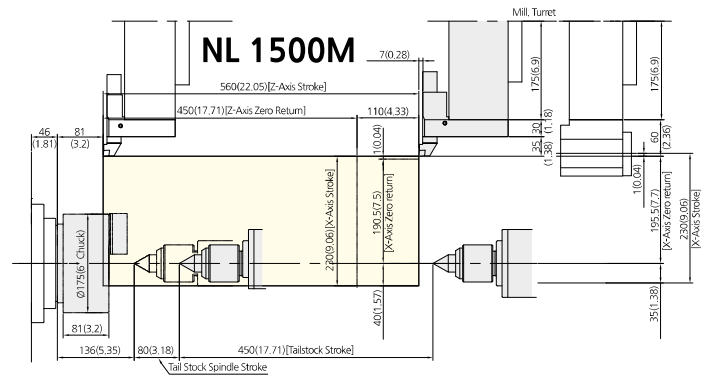
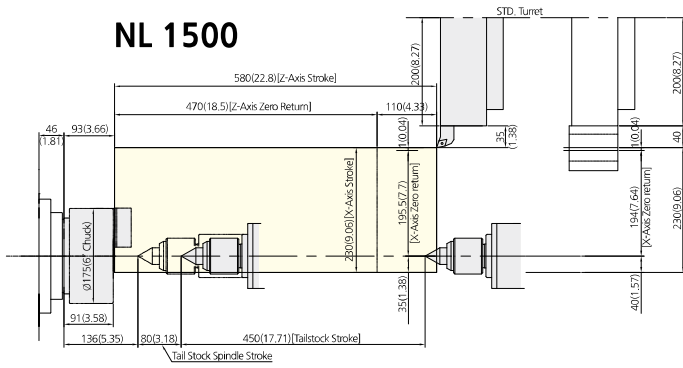

NL 2500S

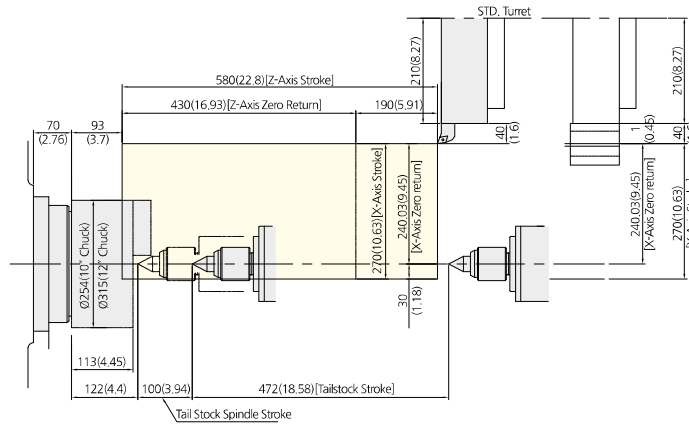

NL 2500SM

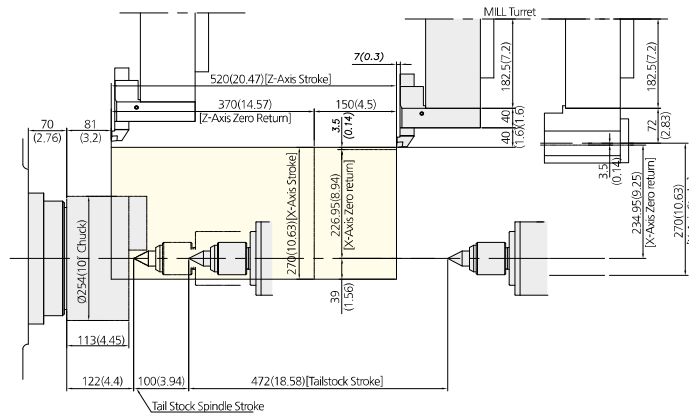

**NL 2500
NL 3000B**

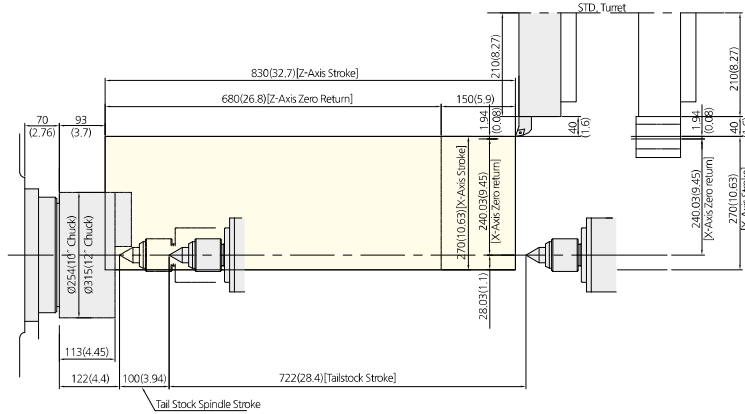

**NL 2500M
NL 3000BM**

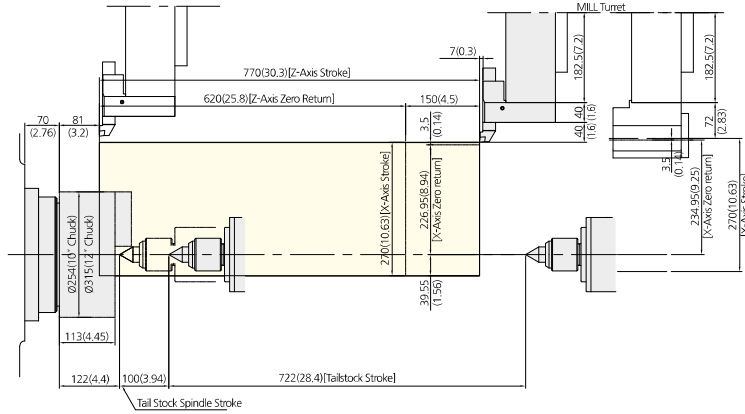

**NL 2500L
NL 3000BL**

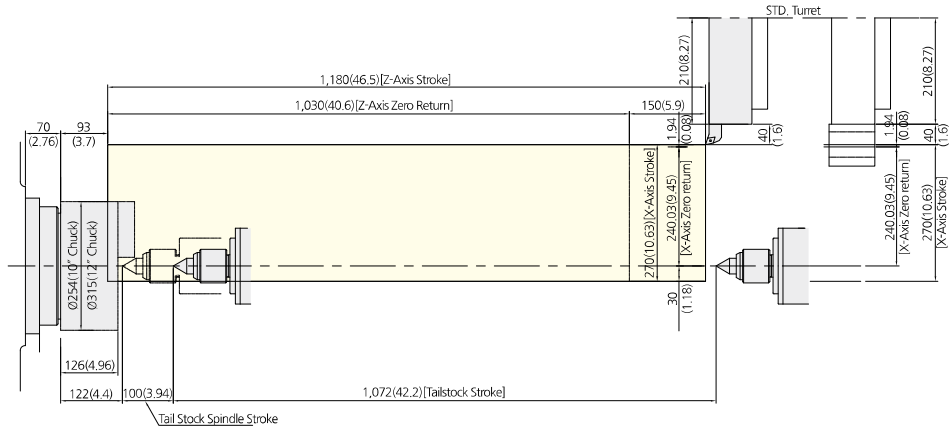

**NL 2500LM
NL 3000BLM**

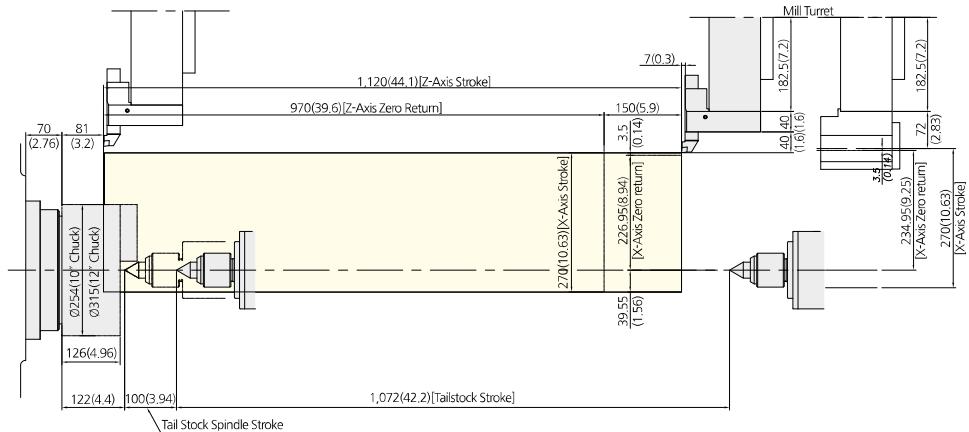

Machine Specifications

DESCRIPTION			NL 1500	NL 1500M	NL 2000	NL 2000M	NL 2000B	NL 2000BM
CAPACITY	Swing over the bed	mm(inch)	570(22.44)					
	Swing over the cross slide	mm(inch)	370(14.57)					
	Max. machining diameter	mm(inch)	391(15.39)	381(15.0)	391(15.39)	381(15.0)	391(15.39)	381(15.0)
	Max. machining length	mm(inch)	560(22.05)	540(21.26)	560(22.05)	540(21.26)	550(21.65)	540(21.26)
	Chuck size	inch	6		8		10	
	Bar working dia.	mm(inch)	51(2.01)		67(2.64)		81(3.19)	
SPINDLE	Spindle speed	rpm	6,000		4,500		3,500	
	Spindle motor	kW(Hp)	11/18.5(15/25)		15/18.5(20/25)			
	Spindle nose	ASA	A2-5		A2-6		A2-8	
	Spindle torque	N.m(ft.lbs)	157(115.8)		336(247.8)		447(329.7)	
	Spindle through hole dia.	mm(inch)	61(2.4)		76(2.99)		91(3.58)	
TRAVEL	Rapid traverse (X/Z)	m/min(ipm)	24/30(945/1,181)					
	X-axis travel	mm(inch)	230(9.06)					
	Z-axis travel	mm(inch)	580(22.83)	560(22.05)	580(22.83)	560(22.05)	580(22.83)	560(22.05)
	Feed motor (X/Z)	kW(hp)	1.8/3(2.4/4)	3/3(4/4)	1.8/3(2.4/4)	3/3(4/4)	1.8/3(2.4/4)	3/3(4/4)
TURRET	Number of tool stations	st.	12					
	OD tool size	mm(inch)	□25(□1)					
	Max. boring bar size	mm(inch)	40(1.5)				50(2)	40(1.5)
	Indexing time	sec	0.15					
	Milling tool holder type	-	-	BMT55	-	BMT55	-	BMT55
	Max. rotary tool spindle speed	rpm	-	5,000	-	5,000	-	5,000
	Rotary tool motor power	kW(hp)	-	3.7/5.5(5/7.4)	-	3.7/5.5(5/7.4)	-	3.7/5.5(5/7.4)
TAILSTOCK	Tailstock travel	mm(inch)	450(17.7)					
	Quill diameter	mm(inch)	80(3.15)					
	Quill travel	mm(inch)	80(3.15)					
	Taper of tailstock spindle	-	MT#4 Live center					
BED TYPE	-	45° Slant						
ELECTRIC POWER SUPPLY	kVA	31						
REQUIRED FLOOR SPACE	mm(inch)	3,140×1,560(124×62)						
MACHINE WEIGHT	kg(lbs)	3,800(8,378)			3,900(8,598)			
CONTROLLER		Fanuc Oi-TF Plus						

{ } : Option

DESCRIPTION			NL 2500S	NL 2500SM	NL 2500[L]	NL 2500M [LM]	NL 3000B [BL]	NL 3000BM [BLM]	
CAPACITY	Swing over the bed	mm(inch)	700(27.56)						
	Swing over the cross slide	mm(inch)	510(20.08)						
	Max. machining diameter	mm(inch)	480(18.9)	450(17.72)	480(18.9)	450(17.72)	480(18.9)	450(17.72)	
	Max. machining length	mm(inch)	530(20.87)	480(18.9)	750(29.53) [1,100(43.31)]	700(27.56) [1,050(41.34)]	750(29.53) [1,100(43.31)]	700(27.56) [1,050(41.34)]	
	Chuck size	inch	10				12		
	Bar working dia.	mm(inch)	81(3.19)				102(4.02)		
SPINDLE	Spindle speed	rpm	3,500 {4,000}				2,800		
	Spindle motor	kW(Hp)	15/18.5(20/25) {22/35(29.5/47)}				22/35(29.5/47)		
	Spindle nose	ASA	A2-8				A2-11		
	Spindle torque	N.m(ft.lbs)	1,256(926.4) {1,336(985.4)}				1,630(1,202.2)		
	Spindle through hole dia.	mm(inch)	91(3.58)				115(4.53)		
TRAVEL	Rapid traverse (X/Z)	m/min(ipm)	24/30(945/1,181)						
	X-axis travel	mm(inch)	270(10.63)						
	Z-axis travel	mm(inch)	580(22.83)	520(20.47)	830(32.68) [1,180(46.46)]	770(30.31) [1,120(44.09)]	830(32.68) [1,180(46.46)]	770(30.31) [1,120(44.09)]	
	Feed motor (X/Z)	kW(hp)	4/4(5.4/5.4)						
TURRET	Number of tool stations	st.	12						
	OD tool size	mm(inch)	□25(□1)						
	Max. boring bar size	mm(inch)	50(2)						
	Indexing time	sec	0.2						
	Milling tool holder type	-	-	BMT65	-	BMT65	-	BMT65	
	Max. rotary tool spindle speed	rpm	-	5,000	-	5,000	-	5,000	
	Rotary tool motor power	kW(hp)	-	3.7/5.5/7.5 (5/7.4/10)	-	3.7/5.5/7.5 (5/7.4/10)	-	3.7/5.5/7.5 (5/7.4/10)	
TAILSTOCK	Tailstock travel	mm(inch)	472(18.58)		722(28.43) [1,072(42.2)]				
	Quill diameter	mm(inch)	110(4.33)						
	Quill travel	mm(inch)	100(3.94)						
	Taper of tailstock spindle	-	MT#4(Built-in)						
BED TYPE	-	45° Slant							
ELECTRIC POWER SUPPLY	kVA	35 {40}					40		
REQUIRED FLOOR SPACE	mm(inch)	3,208×1,778(126.3×70)			3,708×1,727(146×68) [4,013×1,727(158×68)]				
MACHINE WEIGHT	kg(lbs)	4,700(10,361)			5,700(12,566) [6,900(15,211)]				
CONTROLLER		Fanuc Oi-TF Plus							

SMART
MACHINE TOOL

NL 1500/2000/2500/3000
CNC Turning Centers

22 - 23

Machine specifications

NC Unit Specifications / FANUC Series

● : Standard features ○ : Option

Item		Specification	Oi-TF Plus
Controlled axis	Max. feed axes		2(B) AXIS
	Feed axes		X/Z/(Cs)
	Max. simultaneously controlled axis		4
	Least command increment	0.001mm / 0.0001"	●
Operation functions	Pulse handle feed	X1, X10, X100	●
	Feedrate per minute	G98	●
	Feedrate per revolution	G99	●
Interpolation functions	Linear interpolation	G01	●
	Circular interpolation	G02, G03	●
	Dwell	G04	●
	Polar coordinate interpolation	G12.1, G13.1	●
	Cylindrical interpolation	G07.1	●
	Variable lead thread cutting	G34	●
	Continuous threading		●
	Reference position return	G28	●
Reference position return check	G27	●	
Feed function	Rapid traverse rate override	F0, 25%, 50%, 100%	●
	Feedrate override	0 ~ 200%	●
Spindle function	Spindle orientation		●
	Rigid tapping		●
	Arbitrary speed threading		○
Program input	Absolute/incremental programming		●
	Multiple repetitive canned cycle	G70 ~ G76	●
	Canned cycles	G90, G92, G94	●
	Inch/metric conversion	G20 / G21	●
	Program restart		●
	Retraction for rigid tapping		○
	Max. programmable dimension	±999999.999mm/±99999.9999	●
	M function	M3 digit	●
	Custom macro		●
	Canned cycle for drilling		●
	Direct drawing dimension programming		●
	Programmable data input	G10	●
	Optional block skip		●
	Workpiece coordinate system	G52 ~ G59	●
Number of registerable programs		400EA	
Setting and display	Alarm & Operator history display		●
	Run hour and parts count display		●
	Display spindle & servo overload		●
	Self-diagnosis function		●
	Extended part program editing		●
Display screen		10.4" color	
Data input/output	Memory card input/output		●
	USB memory input/output		●
Editing operation	Part program storage size	512Kbyte(1280m)	●
Manual guide i	Manual Guide i		○



SMART Machine Tool Korea / R&D center / Factory

115-28, Techno valley 1-ro, Jillye-myeon, Gimhae-si,
Gyeongsangnam-do, Republic of Korea
TEL : +82-55-342-7972 | FAX : +82-55-342-7970
E-mail : smtk@smtkor.com
www.smtkor.com

SMART Machine Tool America

N25W23287 Paul Rd, Pewaukee, WI 53072, USA
TEL : 1-855-637-3320
FAX : 1-262-521-1244
www.smartmachinetool.com