

SMART
MACHINE TOOL

NL 4000/5000/6000

High performance CNC Turning Centers



INAXES
CNC MACHINERY

WWW.CNC-INAXES.CZ

NL Series
NL 4000, NL 5000, NL 6000

Chuck Size
18, 21, 24 Inch

NL Series

Designed by Smart Machine Tool engineers with many years of experience, NL Series turning centers guarantee ultra-high precision, flexible, and reliable machining performance.



NL 4000 | 4000M

NL 4000L | 4000LM

Swing Over Bed	mm(inch)	790(31.10")	Swing Over Bed	mm(inch)	790(31.10")
Max. Machining Length	mm(inch)	1,213(47.76") 1,145(45.08")	Max. Machining Length	mm(inch)	2,213(87.13") 2,145(84.45")
Chuck Size	inch	18"	Chuck Size	inch	18"
Bar Capacity	mm(inch)	116.5(4.59")	Bar Capacity	mm(inch)	116.5(4.59")
Spindle Speed	rpm	2,000	Spindle Speed	rpm	2,000
Motor (Cont./Max)	kW(HP)	30/45(40/60)	Motor (Cont./Max)	kW(HP)	30/45(40/60)
Travel (X/Z)	mm(inch)	340/1,300(13.4"/51.2")	Travel (X/Z)	mm(inch)	340/2,300(13.4"/90.6")
No. of Tools	EA	12	No. of Tools	EA	12

Content

- 02 Product Preview
- Basic Information
- 06 Machine Structure
- 13 SMART Operation Features
- Machine Specification
- 16 Standard/Option Specifications
- 28 Machine Specifications



NL 5000 | 5000M

Swing Over Bed	mm(inch)	900(35.43")
Max. Machining Length	mm(inch)	1,155(45.47") 1,119(44.06")
Chuck Size	inch	21"
Bar Capacity	mm(inch)	165.5(6.52")
Spindle Speed	rpm	1,500
Motor (Cont./Max)	kW(HP)	30/45 (40/60)
Travel (X/Z)	mm(inch)	350/1,300(13.8"/51.2")
No. of Tools	EA	12

NL 5000L | 5000LM

Swing Over Bed	mm(inch)	900(35.43")
Max. Machining Length	mm(inch)	2,155(84.84") 2,119(83.43")
Chuck Size	inch	21"
Bar Capacity	mm(inch)	165.5(6.52")
Spindle Speed	rpm	1,500
Motor (Cont./Max)	kW(HP)	30/45 (40/60)
Travel (X/Z)	mm(inch)	350/2,300(13.8"/90.6")
No. of Tools	EA	12

NL 4000 | 5000 | 6000

- 45° slanted torque tube design bed and wide slideway for high rigidity machining
- Wide box guideways machined from one-piece casting promote heavy duty cutting
- High torque AC servo motor ensures fast indexing time and repeatability
- Excellence rapid traverse rate
- High spindle power ensures powerful cutting capability
- User-friendly operation panel design for efficient machine operation
- Various peripheral equipment and options



NL 6000S | **6000SM**

Swing Over Bed	mm(inch)	1,030(40.55")
Max. Machining Length	mm(inch)	750(29.53") 700(27.56")
Chuck Size	inch	24"
Bar Capacity	mm(inch)	165.5(6.52")
Spindle Speed	rpm	1,200
Motor (Cont./Max)	kW(HP)	37/55 (50/73)
Travel (X/Z)	mm(inch)	475/800(18.7"/31.5")
No. of Tools	EA	12

NL 6000 | **6000M**

Swing Over Bed	mm(inch)	1,030(40.55")
Max. Machining Length	mm(inch)	1,550(61.02") 1,500(59.06")
Chuck Size	inch	24"
Bar Capacity	mm(inch)	165.5(6.52")
Spindle Speed	rpm	1,200
Motor (Cont./Max)	kW(HP)	37/55 (50/73)
Travel (X/Z)	mm(inch)	475/1,600(18.7"/63")
No. of Tools	EA	12

NL 6000L | **6000LM**

Swing Over Bed	mm(inch)	1,030(40.55")
Max. Machining Length	mm(inch)	2,250(88.58") 2,200(86.61")
Chuck Size	inch	24"
Bar Capacity	mm(inch)	165.5(6.52")
Spindle Speed	rpm	1,200
Motor (Cont./Max)	kW(HP)	37/55 (50/73)
Travel (X/Z)	mm(inch)	475/2,300(18.7"/90.55")
No. of Tools	EA	12

NL 6000XL | **6000XLM**

Swing Over Bed	mm(inch)	1,030(40.55")
Max. Machining Length	mm(inch)	3,250(127.95") 3,200(125.98")
Chuck Size	inch	24"
Bar Capacity	mm(inch)	165.5(6.52")
Spindle Speed	rpm	1,200
Motor (Cont./Max)	kW(HP)	37/55 (50/73)
Travel (X/Z)	mm(inch)	475/3,300(18.7"/129.92")
No. of Tools	EA	12



Machine Structure

High Rigidity Body Structure for Heavy-duty Machining



One-Piece Casting Bed

One-piece 45-degree slant bed made out of Meehanite cast iron, which has superb vibration absorption characteristics, provides rigid foundation for all machine components. Such design endures long-term machining accuracy and consistency. In addition, 45-degree slant bed design provides operators with convenient access to the workpiece and superb chip discharge.

01

- Precision hand scraping of contact surfaces of all slides, headstock and tailstock with the bed ensure long-lasting machining accuracy and minimal surface wears.



02

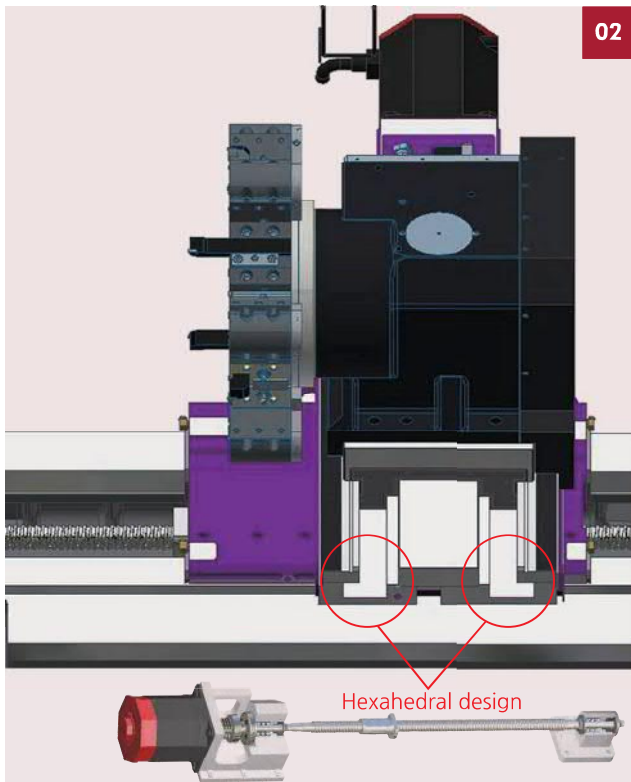

Axis High Performance Motor

Axis is equipped with high performance feed motor for better travel ability, excellence rapid traverse rate, smooth and precise axis movement.

Wide box guideways and Carriage

Hexahedral design and wide box guideways, machined from one piece casting, promote heavy duty machining. Induction hardened and precision ground ways ensure accurate machining for extended period of time. Wide carriage promotes less vibration and allows high precision machining.

Pre-tensioned Ballscrews

All axes ballscrews are pre-tensioned, heat treated and fixed by double anchors on both ends, providing ultimate rigidity and minimal thermal growth.

03

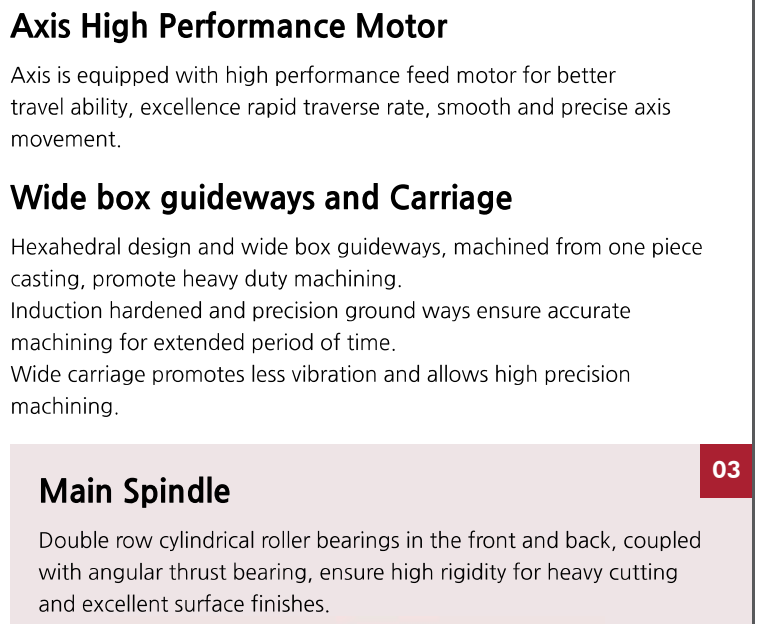

Main Spindle

Double row cylindrical roller bearings in the front and back, coupled with angular thrust bearing, ensure high rigidity for heavy cutting and excellent surface finishes.

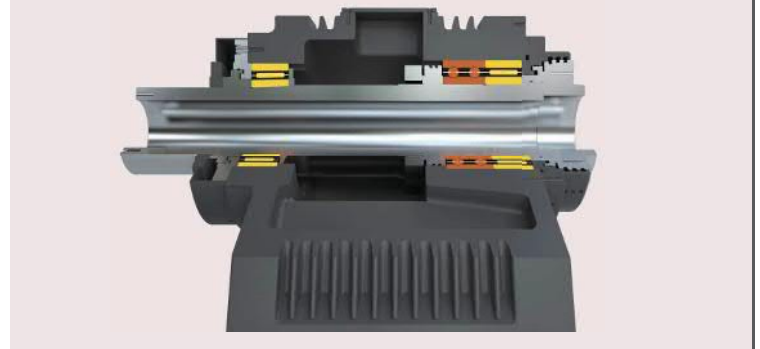

04

12-Station Turret

Large diameter 3-piece Curvic coupling for excellence rigidity and extended tool life. High torque AC servo motor driven ensure fast indexing time, excellence position and repeatability.



05

Programmable Tailstock Body & Quill

Wide-spaced guideways and heavy-duty tailstock body design ensure machining rigidity, and built in spindle quill design ensures higher rigidity.

NL 4000/5000

- Quill Type : **MT#5**
- Quill Dia. : **Ø140mm**
- Quill Travel : **120mm**

NL 6000

- Quill Type : **MT#6**
- Quill Dia. : **Ø180mm**
- Quill Travel : **150mm**



Hex Main Spindle

High Accuracy & Performance CNC Turning Center



Main Spindle

Heavy-duty headstock machined from one-piece casting. Reinforced with radiator fan-like pin tube rib design dissipates heat generated by axis movements, maintaining minimal thermal expansion.

		NL 4000	NL 5000	NL 6000
Chuck size	inch	18"	21"	24"
Spindle Nose	ASA	A2-11	A2-15	A1-15
Max Speed	rpm	2,000	1,500	1,200
Thru Hole Dia.	mm(inch)	Ø132(5.20)	Ø181(7.125)	Ø181(7.125)
Draw tube I.D.	mm(inch)	Ø117.5 (4.63)	Ø166.5(6.56)	Ø166.5(6.56)

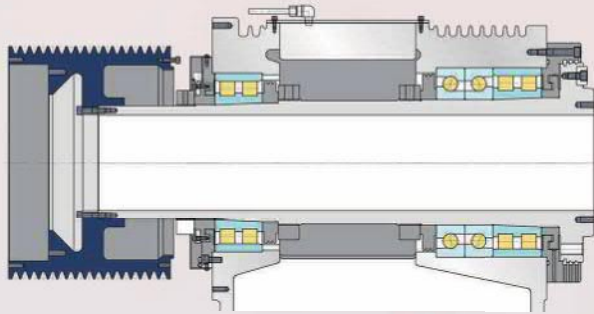

- Spindle pulley system is equipped with powerful and reliable Fanuc AC motor to ensure high torque output and excellence heavy-duty cutting capability.
- V-pulley belts attach to main spindle and gearbox for high power transmission capacity, excellence grip and minimum slip between belt and pulley.
- PK type pulley belt is used to achieve low vibration, low noise and good surface roughness cutting result even at high speed.



Two-Speed Gearbox Std.

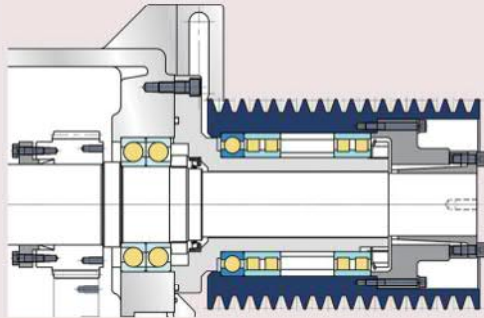

■ NL 4000/5000/6000 are equipped with two-speed gearbox, provide powerful spindle output power and torque.

NL 4000 : 2,000 rpm

Max. Output	Max. Torque
45 kW [60 HP]	3,283 N.m [2,421 lbf.ft]

NL 5000 : 1,500 rpm

Max. Output	Max. Torque
45 kW [60 HP]	3,955 N.m [2,916 lbf.ft]

NL 6000 : 1,200 rpm

Max. Output	Max. Torque
55 kW [73 HP]	5,143 N.m [3,792 lbf.ft]

■ Spindle Torque Diagram

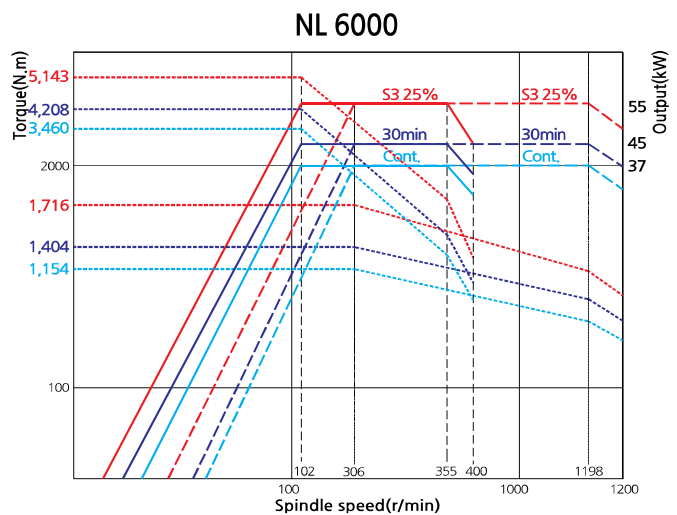
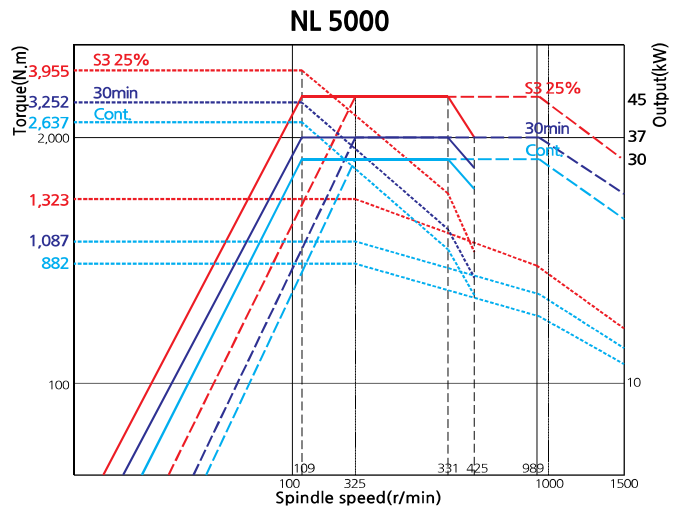
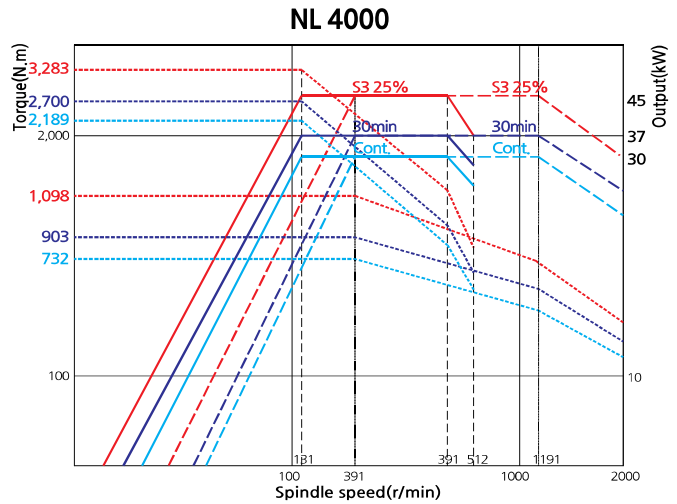

Turret

Finest performance and high precision turret

Standard Turret

Heavy-duty turret driven by high torque AC servo motor for rapid rotation and repeatability. The turret design features large diameter Curvic coupling ensure accurate positioning and strong clamping power.

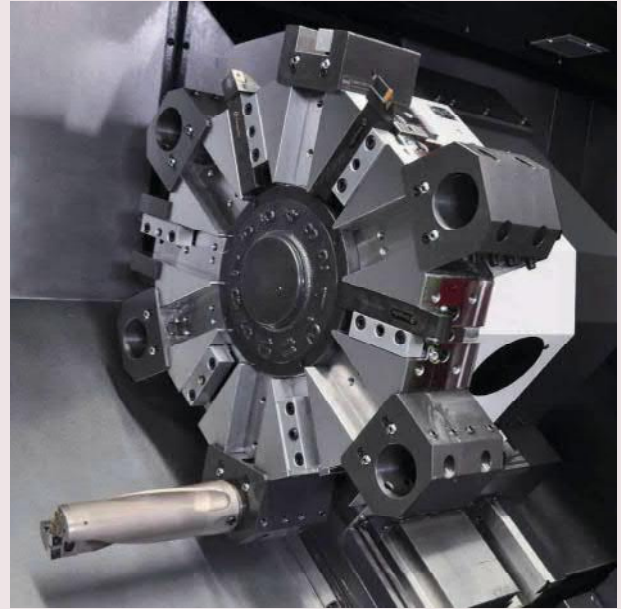
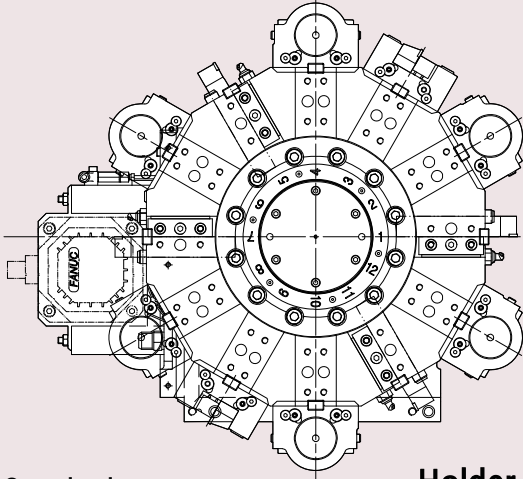

Standard turret

- No. of Tools : 12 EA
- Indexing Time : 0.25 sec

Holder



Boring holder

- NL 4000/5000 : Ø60 (2.5")
- NL 6000 : Ø80 (3")



Bite holder

- 32 (1.25")

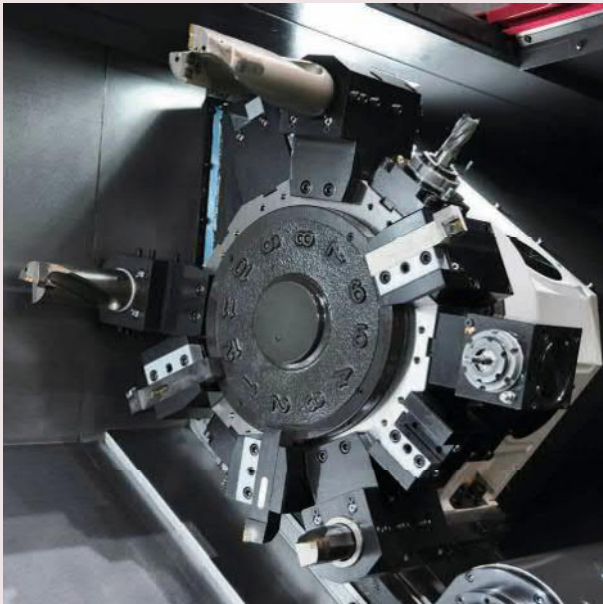

BMT Mill Turret

BMT turret is equipped with 2 separated motors for indexing and milling which improving machining performance and reducing processing time of workpiece.

Mill Tool Holder

Tool holder is mounted to BMT turret by 4 screws ensures stability, rigidity and heavy-duty machining operations.

Straight mill holder



Angular mill holder



■ Mill Tool Torque Diagram

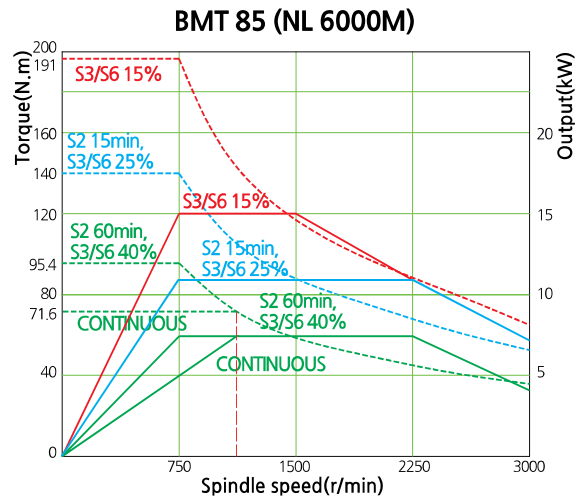
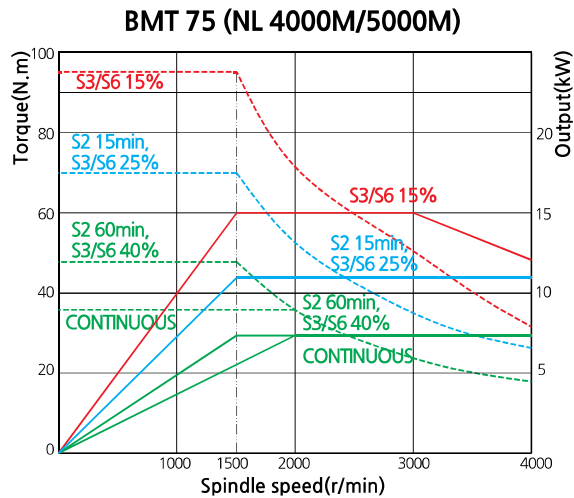

◻ Tailstock

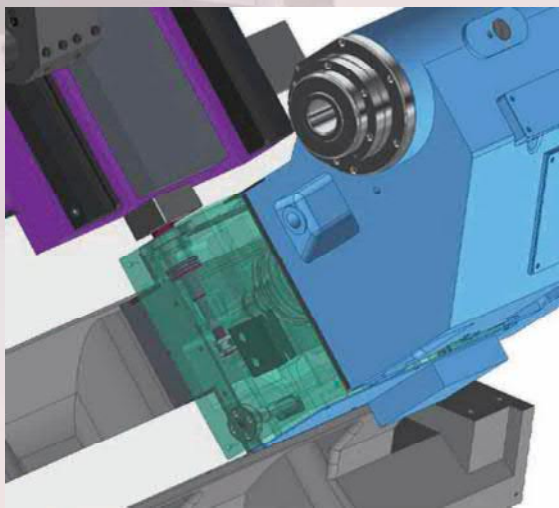

Programmable tailstock body & quill is provided as standard equipment for NL series, make easier to adjust tailstock position and minimize setup time.

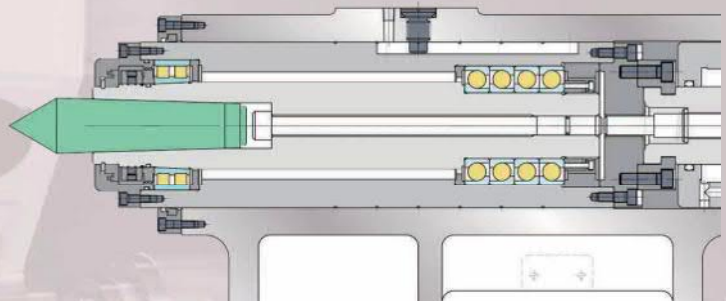

	Tailstock travel	Quill dia.	Quill travel	Taper	Hydraulic clamp	Hydraulic quill
	mm(inch)	mm(inch)	mm(inch)	-	KN	KN
NL 4000/M	1,165(45.87)	Ø140(5.51)	120(4.72)	MT5 (built-in)	72.7 (at 45bar)	26.2 (at 45 bar)
NL 4000L/LM	2,165(85.2)					
NL 5000/M	1,165(45.87)					
NL 5000L/LM	2,165(85.2)					
NL 6000S/SM	Option					
NL 6000/M	1,450(57.09)	Ø180(7.09)	150(5.91)	MT6 (built-in)	271 (at 60 bar)	64 (at 60 bar)
NL 6000L/LM	2,150(84.65)					
NL 6000XL/XLM	3,150(124.02)					

Hex Ballscrew

Ultimate rigidity ballscrew

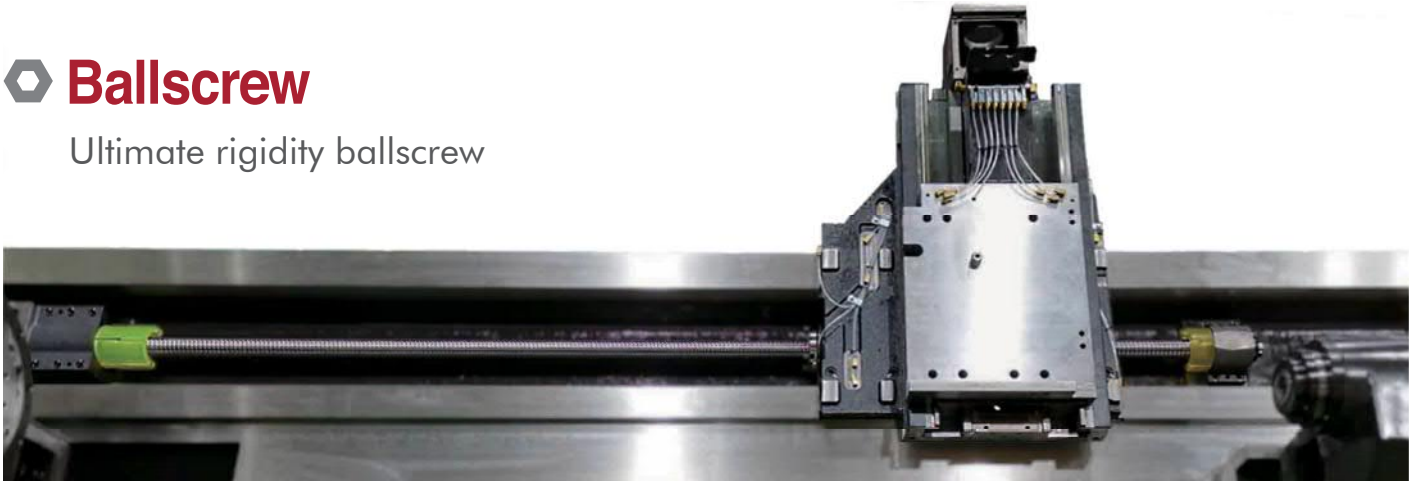

Pre-Tensioned and Double Anchored Ballscrews

Both ends of X-axis and Z-axis are fixed and preloaded with P4 high precision Angular contact ball bearing ensure precise and smooth rotation.

Hex Machining Area

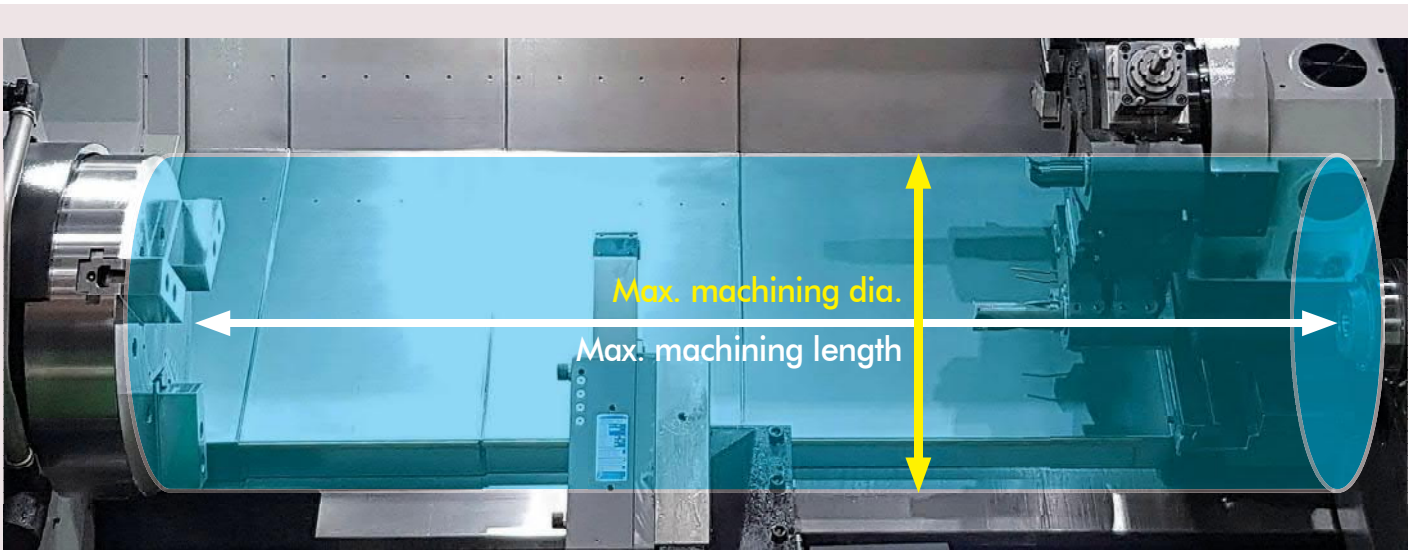

Unit : mm (inch)

Model	Max. machining dia.	Max. machining length	Bar capacity
NL 4000	Ø648 (25.51")	1,213 (47.76")	Ø116.5 (4.59")
NL 4000M	Ø638 (25.11")	1,145 (45.08")	
NL 4000L	Ø648 (25.51")	2,213 (87.13")	
NL 4000LM	Ø638 (25.11")	2,145 (84.45")	
NL 5000	Ø670 (26.38")	1,155 (45.47")	Ø165.5 (6.52")
NL 5000M	Ø650 (25.59")	1,119 (44.06")	
NL 5000L	Ø670 (26.38")	2,155 (84.84")	
NL 5000LM	Ø650 (25.59")	2,119 (83.43")	

Model	Max. machining dia.	Max. machining length	Bar capacity
NL 6000S	Ø960 (37.80")	750 (29.53")	Ø165.5 (6.52")
NL 6000SM	Ø900 (35.43")	700 (27.56")	
NL 6000	Ø960 (37.80")	1,550 (61.02")	
NL 6000M	Ø900 (35.43")	1,500 (59.06")	
NL 6000L	Ø960 (37.80")	2,250 (88.58")	
NL 6000LM	Ø900 (35.43")	2,200 (86.61")	
NL 6000XL	Ø960 (37.80")	3,250 (127.95")	
NL 6000XLM	Ø900 (35.43")	3,200 (125.98")	

SMART Operation Features

Smart NL Series Turning Centers take operator convenience to the next level, offering key optional accessories as standard features of the machines.

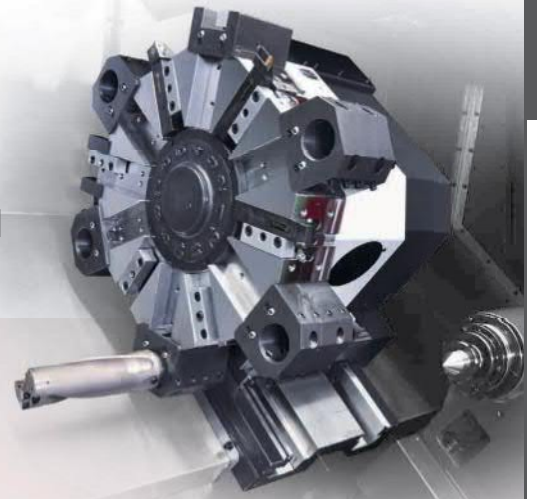

BZi Sensor Std.

SMART provides BZi sensor as standard equipment, instead of position coder, for all models of NL series. Use of BZi sensor helps reduce after sale service cost as BZi sensor does not require maintenance, unlike position coder which need regular service maintenance.

Operator-Friendly Keyboard Layout Std.



- 10.4" color monitor
- Semi-permanent A/S LED lamping
- Waterproof button
- Big button size
- Replaceable button cap
- Light indicator at 100% driving status

Operator-friendly keyboard design for efficient machine operation, with protected sealed buttons to prevent letters and signs from wearing off. Operator panel swivels up to 90 degrees, providing operators with easy access to the panel while working on the machine.

Metered Lubrication System Std.

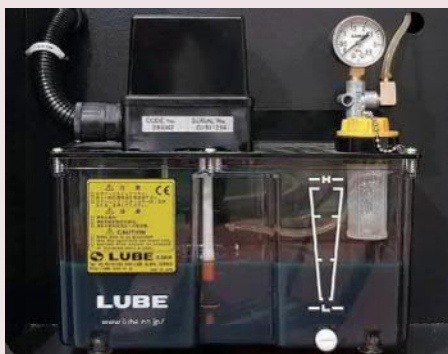

Automatic lubrication dispenser reliably dispenses exact amount of lubrication, only when axes is in operation. In the event of lubrication line failure, the system generates a warning message on CRT and stops the machine for operation safety.

High Pressure Coolant Pump Std. / Oil Skimmer Opt.



Standard high pressure coolant pump sufficiently cools off the heat generated while cutting, ensuring precision machining and extended tool life, while Oil Skimmer effectively removes oil from coolant.



Belt type oil skimmer



Easy plug-in / remove cable

Features

Manual Guide i **Opt.**



MGI enables operators to program and simulate part programs using a conversational programming without actually running the machine.

Tool Presetter **Opt.**



Tool presetter reduces set-up time by minimizing the need for manual skin cuts, measurement, and entering of tool offsets.

Programmable Tailstock and Quill **Std.**

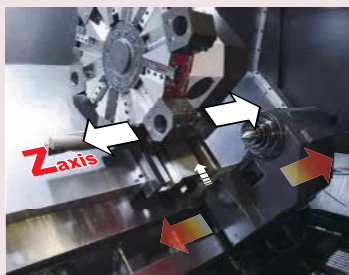

Programmable tailstock and quill make the set-up easier and faster.

Chip Conveyor **Opt.**

Equipped with wide hinged belt, worm gear reducer and torque limiter ensure stable movement and efficiently disposes of chips.

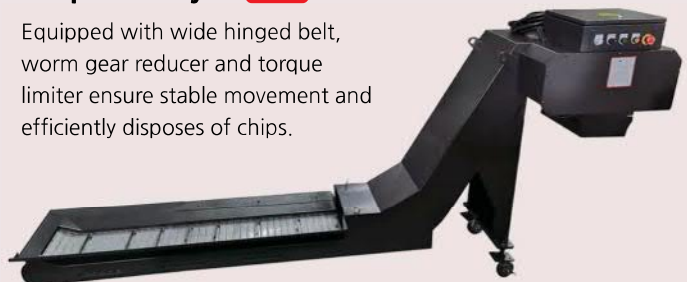

Highly Reliable Electrical Components **Std.**

Brake, power and relay circuits are integrated into one board system to minimize electrical system failure and easily to maintenance and service.

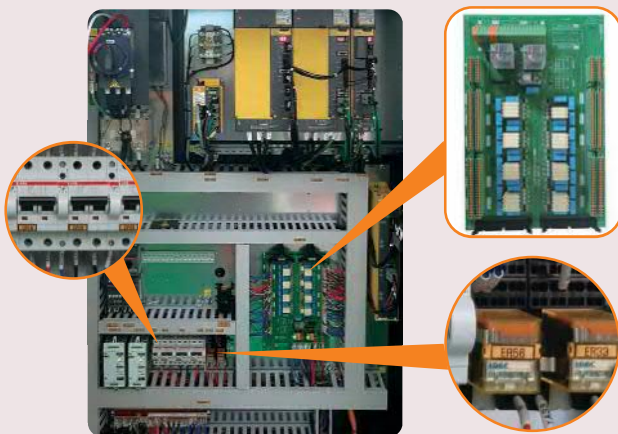

Service Oriented Sheet Metals Design **Std.**

Sheet metals are designed for easy access to the parts/units when service is needed.

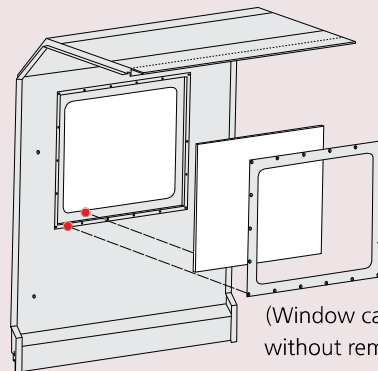

(Window can be replaced without removing the door)

CE Approved Foot Switch **Std.**

Air Gun/Coolant Gun **Opt.**

Connection-ready module design to easily add or remove accessories.





Steady Rest Opt.

Steady rest supports turning long workpiece and prevent workpiece from trembling.

Model	SMW-AUTOBLOK		
	SLU-X 4	SLU-X 5.1	K6
NL 4000	○	×	×
NL 5000	○	×	×
NL 6000	×	○	○

Long Boring Bar Opt.

Long boring bar allows high efficiency deep-hole boring operation.

Model	Boring Bar Holder	
	3"(Ø80)	4"(Ø100)
NL 4000	○	×
NL 5000	○	○
NL 6000	○	○

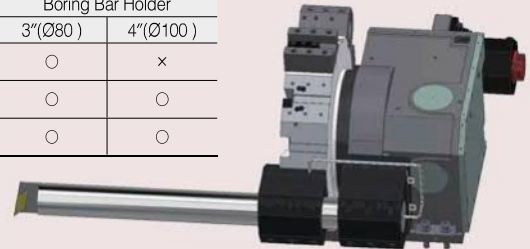

Dual Chuck Opt.

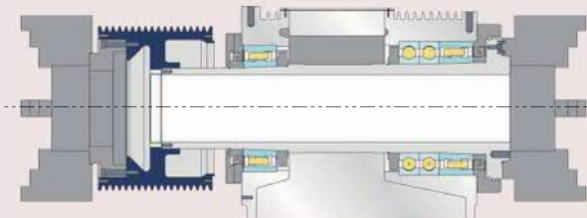

Dual chuck system helps improve machining stability for long workpiece by fix the workpiece at two positions.

Model	Front chuck				Rear chuck	
	Manual		Air		Manual	
	Size	Thru hole	Size	Thru hole	Size	Thru hole
NL 4000	14"	Ø130 (5.12")	-	-	14"	Ø130 (5.12")
NL 5000 NL 6000	18"	Ø190 (7.48")	18"	Ø191 (7.52")	18"	Ø190 (7.48")
NL 6000C	24"	Ø275 (10.83")	24"	Ø275 (10.83")	24"	Ø275 (10.83")

Re-Machining Function Opt.

This function allows user to easily repair damaged part.

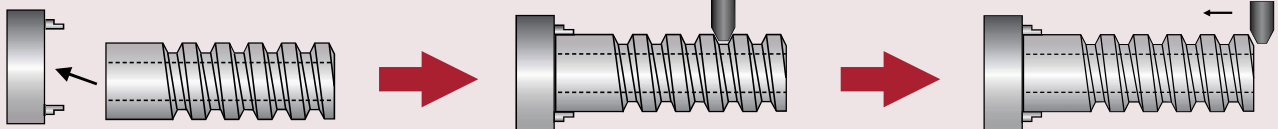

Step 1 : Load the damaged part into the machine.

Step 2 : Manually positioning the tool into the machined thread with the spindle stopped and then registering the position with the CNC.

Step 3 : Retract the tool, start the spindle and run the part program to re-machined the thread.

Arbitrary Speed Threading Opt.

Arbitrary speed threading ensures cutting tool remains coordinated with spindle speed at all time during threading. It allows user to adjust spindle speed during threading without damaging the part.

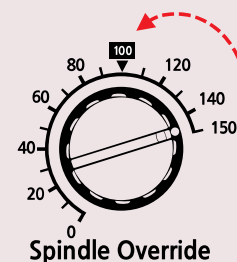
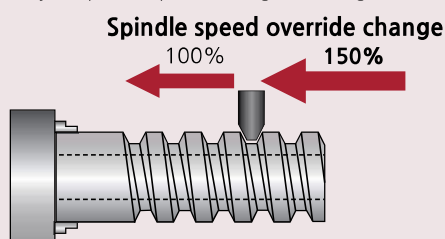

Standard & Option Specifications

● : Standard features ○ : Option X : Not applicable

		NL 6000							
		S	SM	-	M	L	LM	XL	XLM
Spindle and Chucking									
Chuck size	24 inch	●	●	●	●	●	●	●	●
Dual pressure chucking		○	○	○	○	○	○	○	○
Chuck pressure switch		○	○	○	○	○	○	○	○
Chuck clamp foot switch		●	●	●	●	●	●	●	●
Chuck clamp confirmation		●	●	●	●	●	●	●	●
Dual chuck		○	○	○	○	○	○	○	○
2 step gearbox		●	●	●	●	●	●	●	●
Jaw									
Hydraulic Hollow chuck		●	●	●	●	●	●	●	●
Soft jaw	3 set	●	●	●	●	●	●	●	●
Hard jaw	1 set	●	●	●	●	●	●	●	●
Special chuck		○	○	○	○	○	○	○	○
Turret									
Long boring bar	3 inch	○	○	○	○	○	○	○	○
	4 inch	○	○	○	○	○	○	○	○
Steady Rest									
SLU-X 5.1	Ø85~Ø350mm(3.35~13.78inch)	○	○	○	○	○	○	○	○
K 6	Ø135~Ø460mm(5.31~18.11inch)	○	○	○	○	○	○	○	○
Tailstock									
Programmable tailstock		○	○	●	●	●	●	●	●
Tailstock taper	MT#6	○	○	●	●	●	●	●	●
Built-in live center		○	○	●	●	●	●	●	●
Tailstock in-out foot switch		○	○	●	●	●	●	●	●
Coolant									
High pressure coolant pump	10 bar (140 psi)	●	●	●	●	●	●	●	●
Oil skimmer		○	○	○	○	○	○	○	○
Coolant chiller		○	○	○	○	○	○	○	○
Chuck coolant		○	○	○	○	○	○	○	○
Shower coolant		○	○	○	○	○	○	○	○
Coolant gun		○	○	○	○	○	○	○	○
Chip Disposal									
Side chip conveyor		○	○	○	○	○	○	○	○
Chip bucket		○	○	○	○	○	○	○	○
Air gun		○	○	○	○	○	○	○	○
Air blower system		○	○	○	○	○	○	○	○
Measurement & Automatic Operation									
Tool presetter		○	○	○	○	○	○	○	○
Auto door		○	○	○	○	○	○	○	○
Others									
Tri-color operation status light tower		●	●	●	●	●	●	●	●
Work light (LED lamp)		●	●	●	●	●	●	●	●
Manual and part list		●	●	●	●	●	●	●	●
Door interlock		●	●	●	●	●	●	●	●
Tool/work box		●	●	●	●	●	●	●	●
Leveling blocks		●	●	●	●	●	●	●	●
Manual guide i		○	○	○	○	○	○	○	○

NC Unit Specifications / FANUC Series

● : Standard features ○ : Option

	Item	Specification	0i-TF Plus
Controlled axis	Max. feed axes		2(3) AXIS
	Feed axes		X/Z/(Cs)
	Max. simultaneously controlled axis		4
	Least command increment	0.001mm / 0.0001"	●
Operation functions	Pulse handle feed	X1, X10, X100	●
	Feedrate per minute	G98	●
	Feedrate per revolution	G99	●
Interpolation functions	Linear interpolation	G01	●
	Circular interpolation	G02, G03	●
	Dwell	G04	●
	Polar coordinate interpolation	G12.1, G13.1	●
	Cylindrical interpolation	G07.1	●
	Variable lead thread cutting	G34	●
	Continuous threading		●
	Reference position return	G28	●
	Reference position return check	G27	●
Feed function	Rapid traverse rate override	F0, 25%, 50%, 100%	●
	Feedrate override	0 ~ 200%	●
Spindle function	Spindle orientation		●
	Rigid tapping		●
	Arbitrary speed threading		○
Program input	Absolute/incremental programming		●
	Multiple repetitive canned cycle	G70 ~ G76	●
	Canned cycles	G90, G92, G94	●
	Inch/metric conversion	G20 / G21	●
	Program restart		●
	Retraction for rigid tapping		○
	Max. programmable dimension	±999999.999mm/±99999.9999	●
	M function	M3 digit	●
	Custom macro		●
	Canned cycle for drilling		●
	Direct drawing dimension programming		●
	Programmable data input	G10	●
	Optional block skip		●
	Workpiece coordinate system	G52 ~ G59	●
Number of registerable programs		400EA	
Setting and display	Alarm & Operator history display		●
	Run hour and parts count display		●
	Display spindle & servo overload		●
	Self-diagnosis function		●
	Extended part program editing		●
	Display screen		10.4" color
Data input/output	Memory card input/output		●
	USB memory input/output		●
Editing operation	Part program storage size	512Kbyte(1280m)	●
Manual guide i	Manual Guide <i>i</i>		○

Machine Dimensions

Unit : mm (inch)

Top view

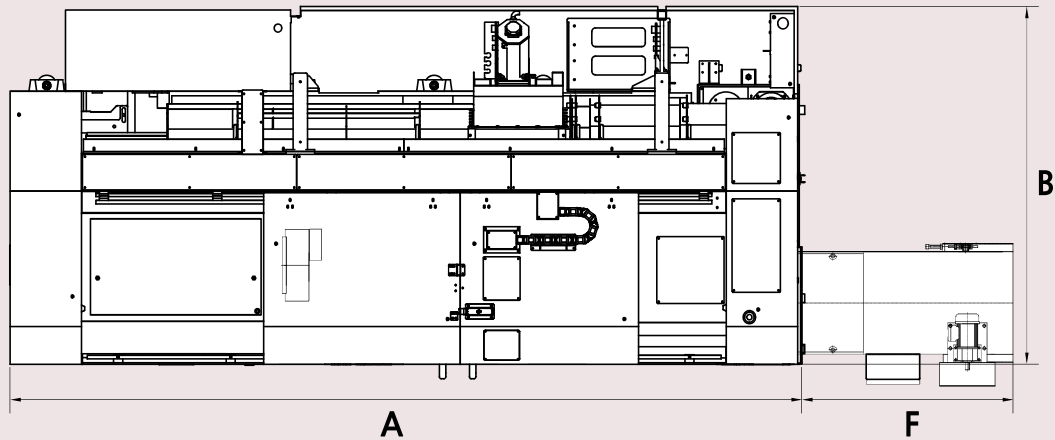

Front view

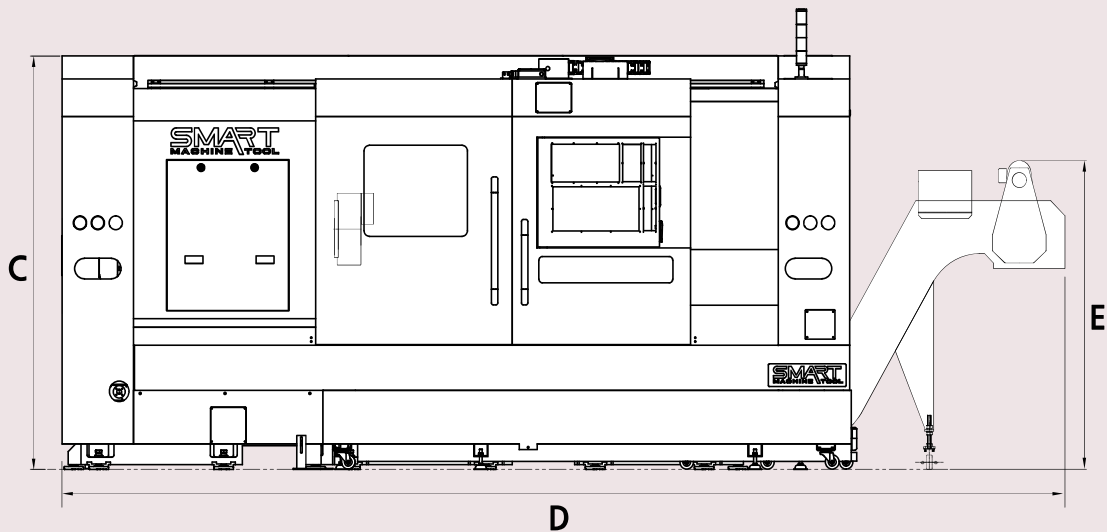

Model	A (Length)	B (Width)	C (Height)	D (Length with side chip conveyor)	E (Chip conveyor height)	F (Side chip conveyor)
NL 4000/M	4,410 (173.6)	1,940 (76.4)	2,268 (89.3)	5,615 (221.1)	1,639.5 (64.5)	1,205 (47.5)
NL 4000L/LM	5,680 (223.6)			6,885 (271.1)		
NL 5000/M	4,410 (173.6)			5,615 (221.1)		
NL 5000/LM	5,680 (223.6)	2,302 (90.6)	2,300 (90.6)	6,885 (271.1)	1,561 (61.5)	1,228 (48.4)
NL 6000S/SM	4,335 (170.7)			5,563 (219.0)		
NL 6000/M	5,135 (202.2)			6,363 (250.5)		
NL 6000L/LM	5,948 (234.2)	2,382 (93.8)	2,380 (93.7)	7,176 (282.5)		
NL 6000XL/XLM	7,043 (277.3)			8,251 (324.8)		

Interference

NL 4000/L
(12 Station Std. Turret)

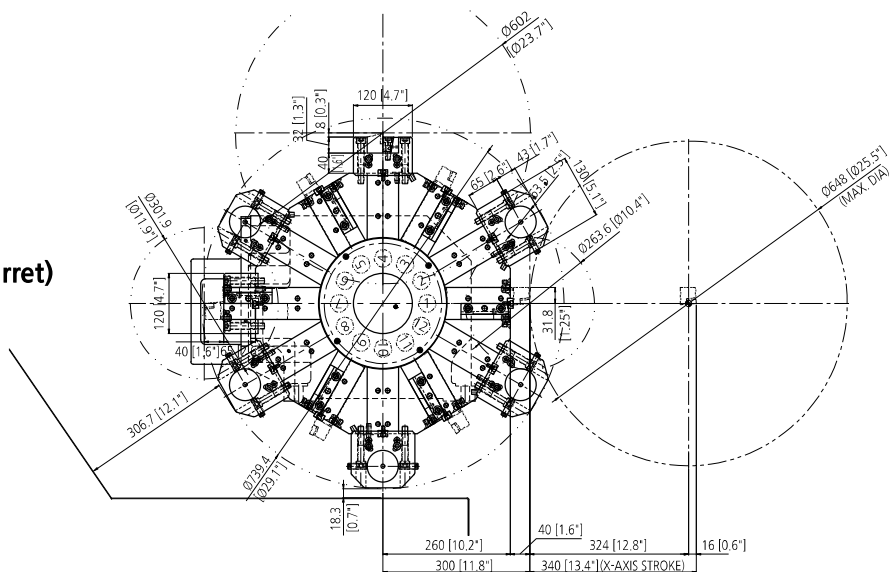

NL 4000M/LM
(BMT75 12 Station Mill Turret)

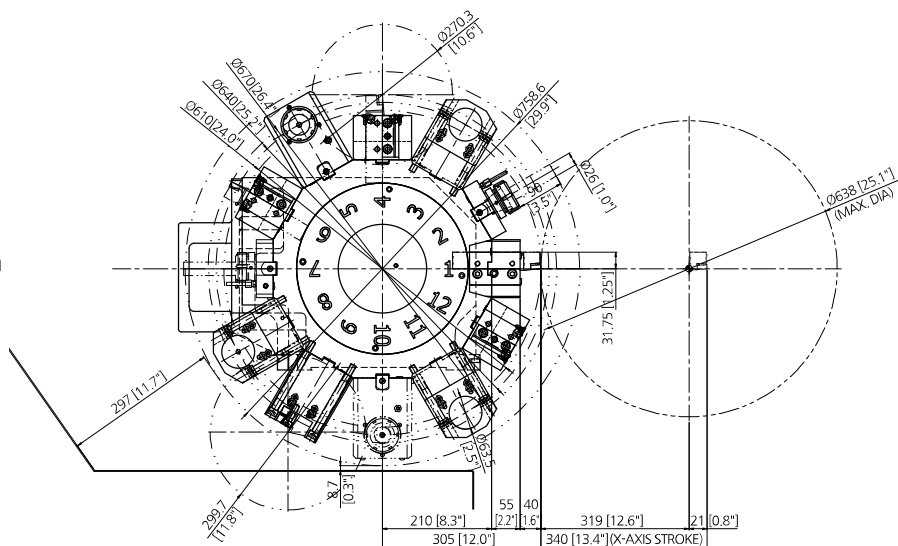

NL 5000/L
(12 Station Std. Turret)

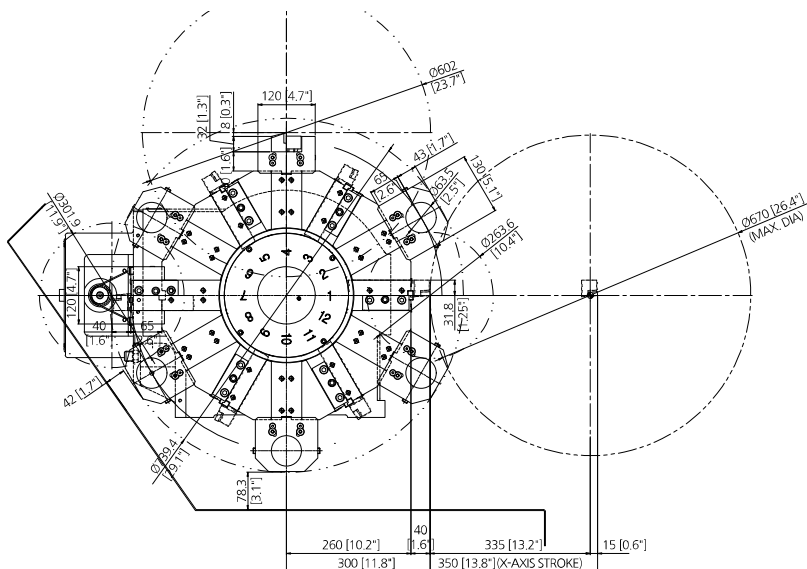

Unit : mm (inch)

**NL 5000M/5000LM
(BMT75 12 Station Mill Turret)**

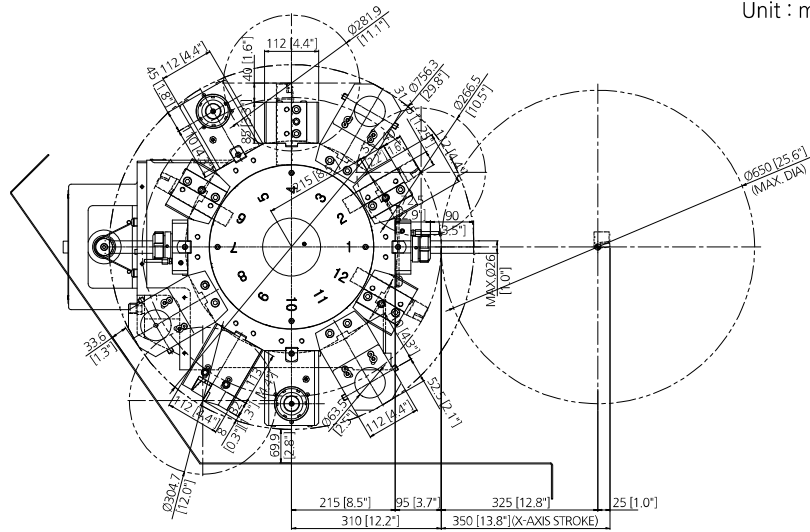

**NL 6000/S/L/XL
(12 Station Std. Turret)**

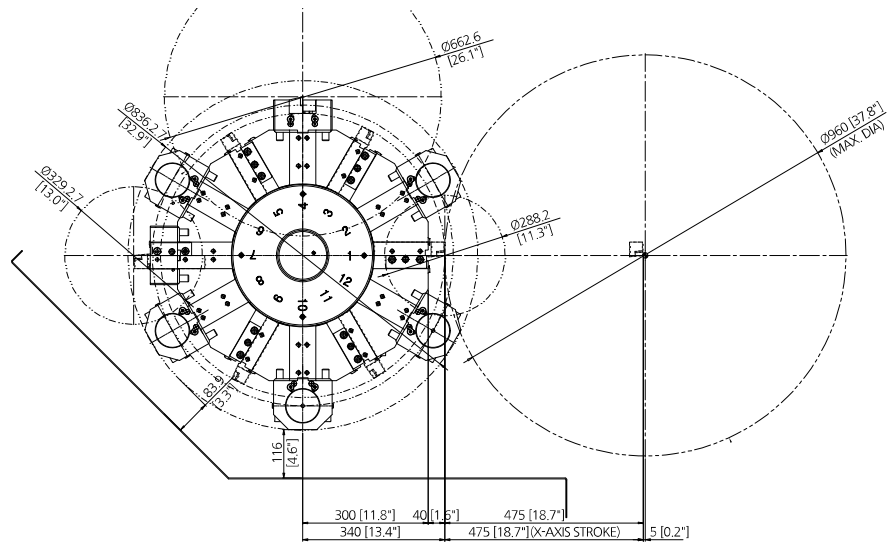

**NL 6000M/SM/LM/XLM
(BMT85 12 Station Mill Turret)**

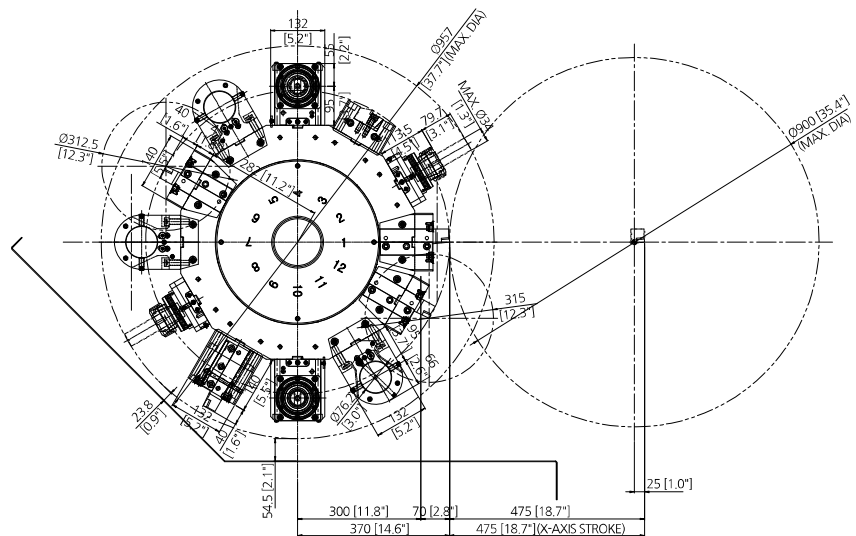

Tooling System

Standard Turret (12 Station)

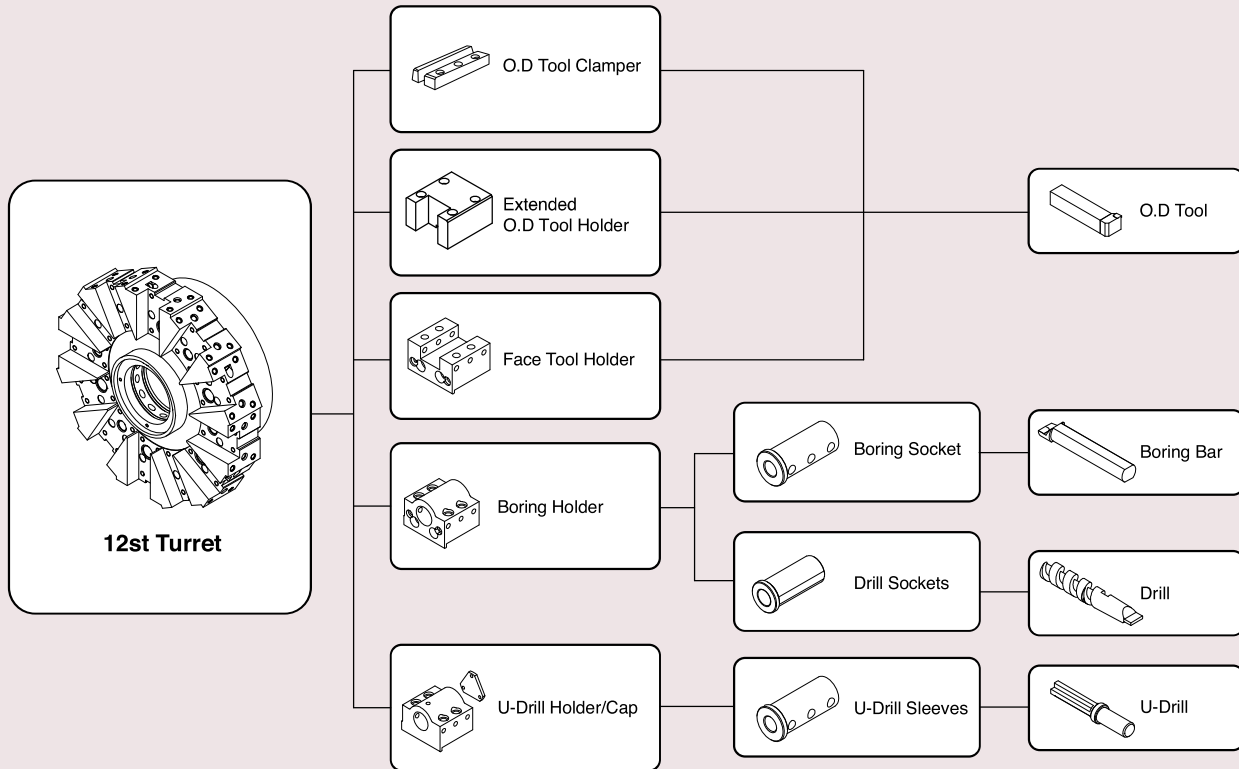

Standard Tooling Parts

Unit : mm(inch)

ITEM/ MODEL		NL 4000/L	NL 5000/L	NL 6000/S/L/XL	
Turning Holder	Extended O.D Holder	1	1	1	
	Facing Holder	1	1	1	
Boring Holder	I.D Holder	Single	-	4	
	U-Drill Holder/Cap	-	5	1	
Driven Holder	Axial Milling Holder	Standard	-	-	
	Radial Milling Holder	Standard	-	-	
Socket	Boring	Ø10(3/8")	-	-	
		Ø12(1/2")	1	1	
		Ø16(5/8")	1	1	
		Ø20(3/4")	1	1	
		Ø25(1")	1	1	
		Ø32(1 1/4")	1	1	
		Ø40(1 1/2")	1	1	
		Ø50(2")	1	1	
	Ø60(2 1/2")	-	-	1	
	Drill	MT2	1	1	1
		MT3	1	1	1
		MT4	1	1	1
MT5		1	1	1	

BMT Turret (12 Station)

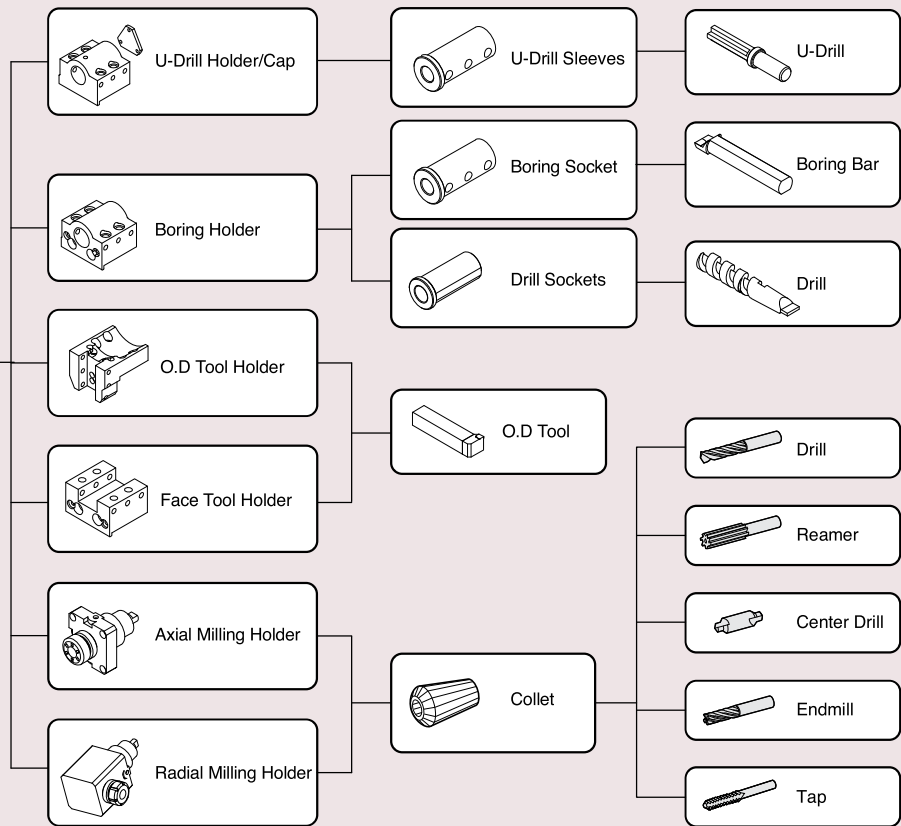
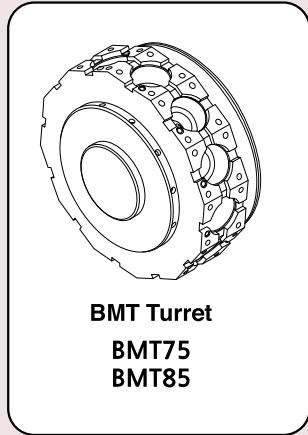

Standard Tooling Parts

Unit : mm(inch)

ITEM/ MODEL			NL 4000M/LM	NL 5000M/LM	NL 6000M/SM/LM/XLM	
Turning Holder	O.D Holder		4	4	4	
	Facing Holder		1	1	1	
Boring Holder	I.D Holder	Single	2	2	2	
	U-Drill Holder/Cap		-	1	1	
Driven Holder	Axial Milling Holder		1	1	1	
	Radial Milling Holder		1	1	1	
Socket	Boring	Ø10(3/8")	-	-	-	
		Ø12(1/2")	1	1	-	
		Ø16(5/8")	1	1	1	
		Ø20(3/4")	1	1	1	
		Ø25(1")	1	1	1	
		Ø32(1 1/4")	1	1	1	
		Ø40(1 1/2")	1	1	1	
		Ø50(2")	1	1	1	
	Ø60(2 1/2")	-	-	1		
	Drill	MT2		1	1	1
		MT3		1	1	1
		MT4		1	1	1
MT5		1	1	1		

Work Range

Unit : mm(inch)

NL 4000

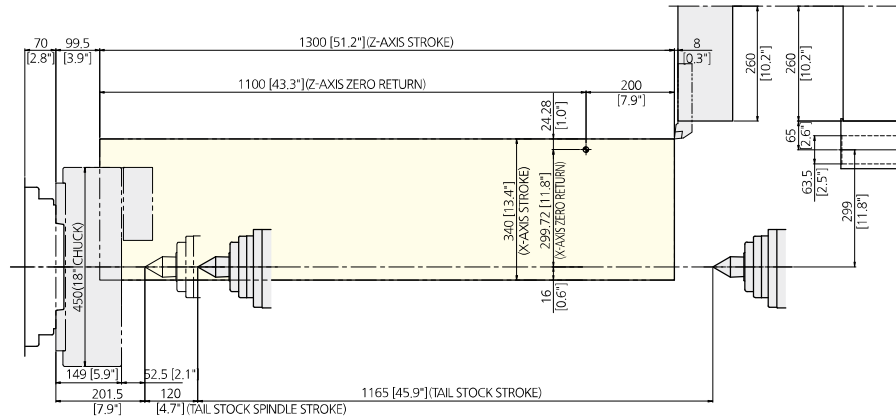

NL 4000M

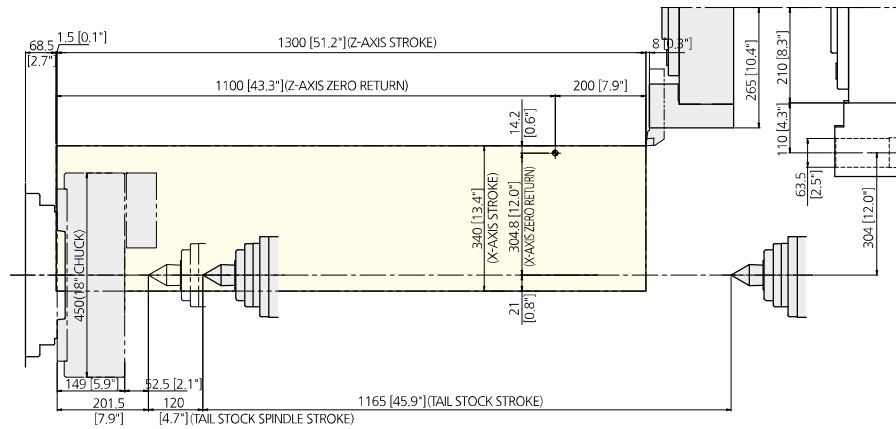

NL 4000L

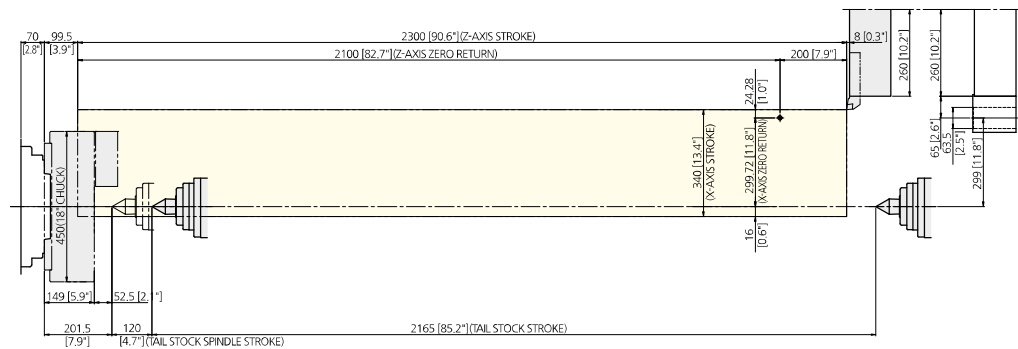

NL 4000LM

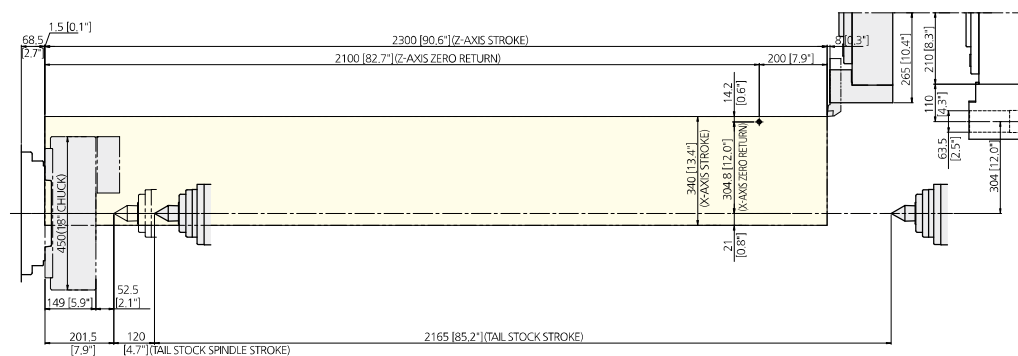

NL 5000

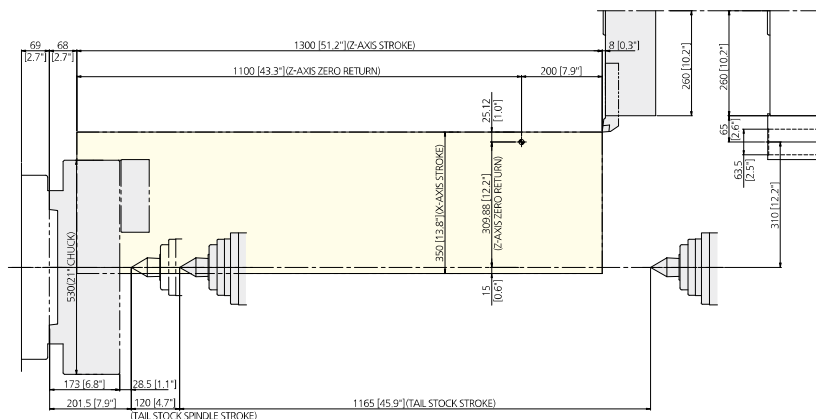

NL 5000M

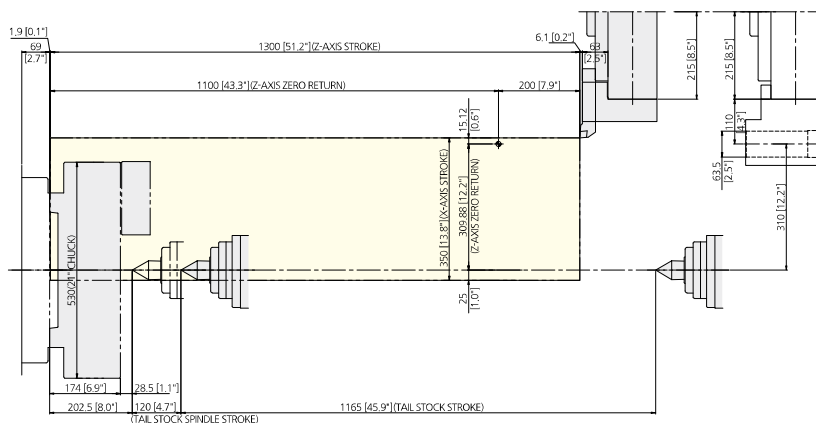

NL 5000L

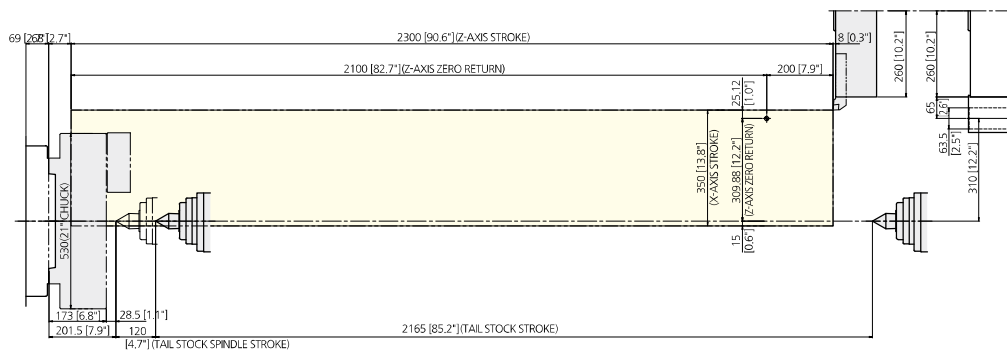

NL 5000LM

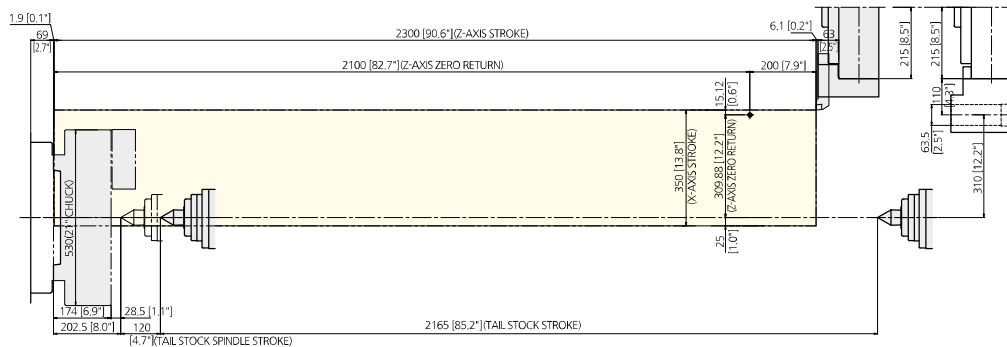

Work Range

Unit : mm(inch)

NL 6000S

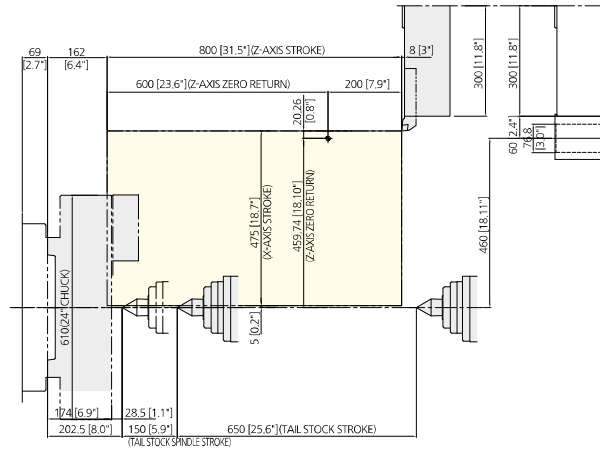

NL 6000SM

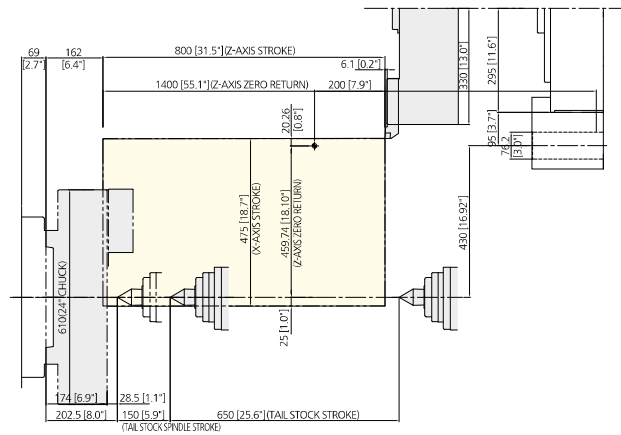

NL 6000

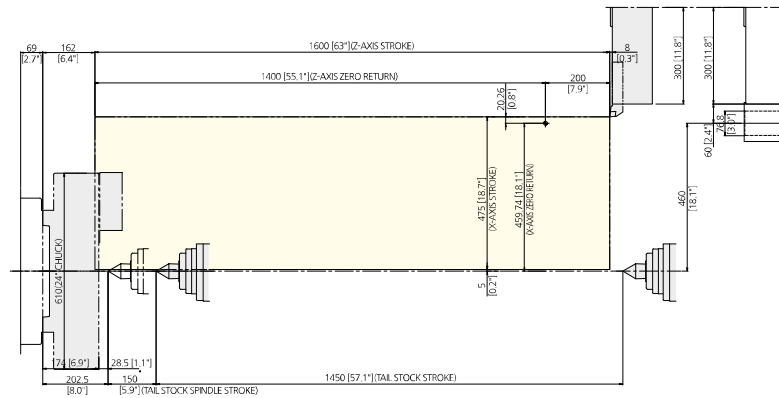

NL 6000M

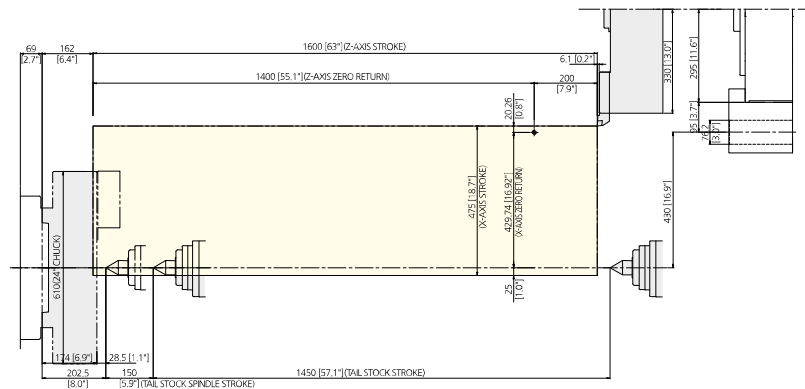

NL 6000L

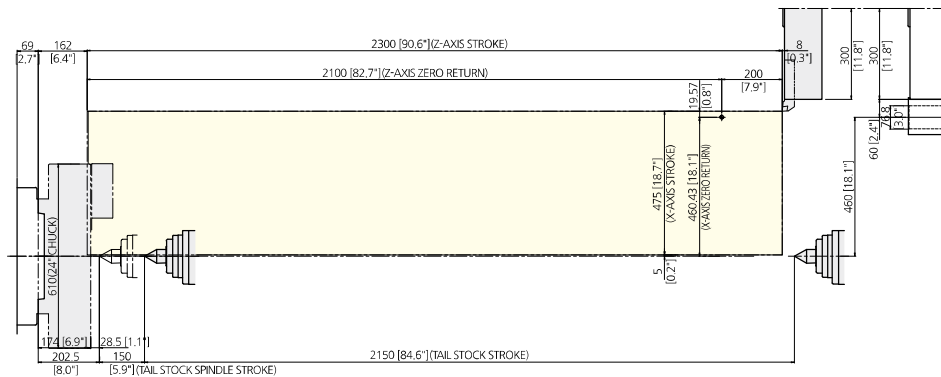

NL 6000LM

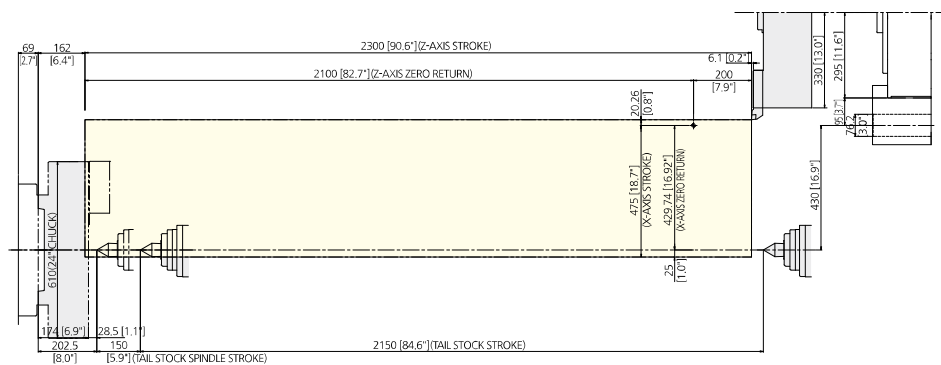

NL 6000XL

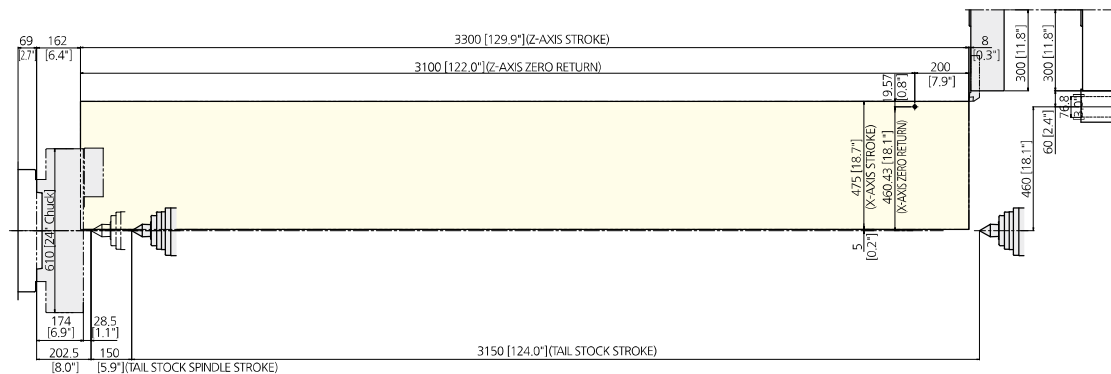

NL 6000XLM

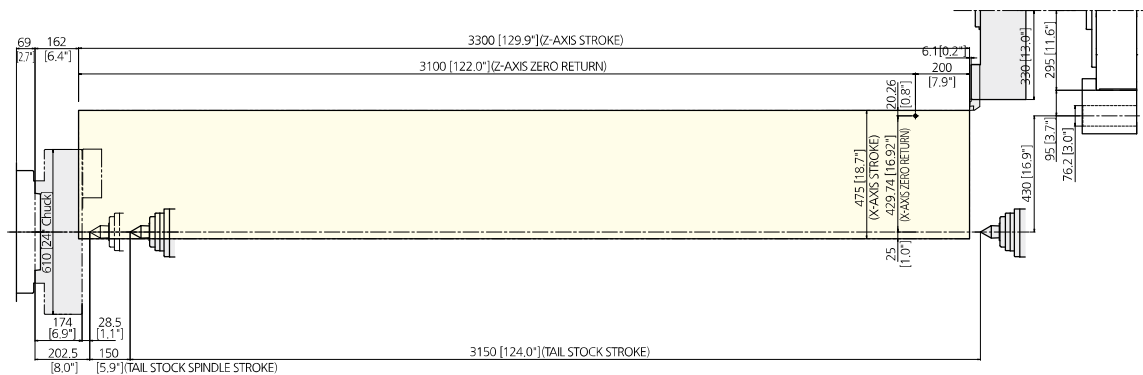

Machine Specifications

DESCRIPTION			NL 4000	NL 4000M	NL 4000L	NL 4000LM
CAPACITY	Swing over the bed	mm(inch)	790 (31.10)			
	Swing over the cross slide	mm(inch)	610 (24.02)			
	Max. machining diameter	mm(inch)	648 (25.51)	638 (25.11)	648 (25.51)	638 (25.11)
	Max. machining length	mm(inch)	1,213 (47.76)	1,145 (45.08)	2,213 (87.13)	2,145 (84.45)
	Chuck size	inch	18			
	Bar working dia.	mm(inch)	116.5 (4.59)			
SPINDLE	Spindle speed	rpm	2,000			
	Spindle motor	kW(Hp)	30/45 (40/60)			
	Spindle nose	ASA	A2 - 11			
	Spindle torque	N.m(ft.lbs)	3,283 (2,421)			
	Spindle through hole dia.	mm(inch)	132(5.2)			
TRAVEL	Rapid traverse (X/Z)	m/min(ipm)	16/20 (630/787)			
	Travel (X/Z)	mm(inch)	340/1,300 (13.39/51.2)		340/2,300 (13.39/90.6)	
	Feed motor (X/Z)	kW(hp)	4/7 (5.4/9.4)			
TURRET	Number of tool stations	st.	12			
	OD tool size	mm(inch)	□32 (□1.25)			
	Max. boring bar size	mm(inch)	60 (2.5)			
	Indexing time	sec	0.25/Step			
	Milling tool holder type	-	-	BMT75	-	BMT75
	Max. rotary tool spindle speed	rpm	-	4,000	-	4,000
	Rotary tool motor power	kW(hp)	-	7.5/11/15 (10/14.8/20.1)	-	7.5/11/15 (10/14.8/20.1)
TAILSTOCK	Tailstock travel	mm(inch)	1,165 (45.87)		2,165 (85.24)	
	Tailstock spindle diameter	mm(inch)	140 (5.51)			
	Taper of tailstock spindle	-	MT#5 (Built-in)			
	Tailstock spindle travel	mm(inch)	120 (4.72)			
BED TYPE	-	45° Slant				
ELECTRIC POWER SUPPLY	kVA	55				
REQUIRED FLOOR SPACE	mm(inch)	4,450(175.2)×2,017(79.4)			5,720(225.2)×2,205(86.8)	
MACHINE WEIGHT	kg(lbs)	10,700 (23,589)	10,800 (23,810)	13,600 (29,983)	13,700 (30,203)	
CONTROLLER		Fanuc Oi-TF Plus				

DESCRIPTION		NL 5000	NL 5000M	NL 5000L	NL 5000LM
CAPACITY	Swing over the bed	900 (35.43)			
	Swing over the cross slide	690 (27.17)			
	Max. machining diameter	670 (26.38)	650 (25.59)	670 (26.38)	650 (25.59)
	Max. machining length	1,155(45.47)	1,119(44.06)	2,155(84.84)	2,119(83.43)
	Chuck size	21			
	Bar working dia.	165.5 (6.52)			
SPINDLE	Spindle speed	1,500			
	Spindle motor	30/45 (40/60)			
	Spindle nose	A2 - 15			
	Spindle torque	3,955 (2,916)			
	Spindle through hole dia.	181(7.125)			
TRAVEL	Rapid traverse (X/Z)	16/20 (630/787)			
	Travel (X/Z)	350/1,300 (13.8/51.2)		350/2,300 (13.8/90.6)	
	Feed motor (X/Z)	7/6 (9.4/8)			
TURRET	Number of tool stations	12			
	OD tool size	□32 (□1.25)			
	Max. boring bar size	60 (2.5)			
	Indexing time	0.25/Step			
	Milling tool holder type	-	BMT75	-	BMT75
	Max. rotary tool spindle speed	-	4,000	-	4,000
	Rotary tool motor power	-	7.5/11/15 (10/14.8/20.1)	-	7.5/11/15 (10/14.8/20.1)
TAILSTOCK	Tailstock travel	1,165 (45.87)		2,165 (85.24)	
	Tailstock spindle diameter	140 (5.51)			
	Taper of tailstock spindle	MT#5 (Built-in)			
	Tailstock spindle travel	120 (4.72)			
BED TYPE	-	45° Slant			
ELECTRIC POWER SUPPLY	kVA	55			
REQUIRED FLOOR SPACE	mm(inch)	4,450(175.2)×2,017(79.4)		5,720(225.2)×2,205(86.8)	
MACHINE WEIGHT	kg(lbs)	10,800 (23,810)	10,900 (24,030)	13,700 (30,203)	13,800 (30,424)
CONTROLLER		Fanuc Oi-TF Plus			

Machine Specifications

DESCRIPTION			NL 6000S	NL 6000SM	NL 6000 [C]	NL 6000M
CAPACITY	Swing over the bed	mm(inch)	1,030 (40.55)			
	Swing over the cross slide	mm(inch)	850 (33.46)			
	Max. machining diameter	mm(inch)	960(37.80)	900(35.43)	960(37.80)	900(35.43)
	Max. machining length	mm(inch)	750 (29.53)	700 (27.56)	1,550(61.02)	1,500(59.06)
	Chuck size	inch	24		24 [user scope]	24
	Bar working dia.	mm(inch)	165.5 (6.52)		165.5 (6.52) [-]	165.5 (6.52)
SPINDLE	Spindle speed	rpm	1,200		1,200 [1,000]	1,200
	Spindle motor	kW(Hp)	37/55 (50/73)			
	Spindle nose	ASA	A1 - 15		A1 - 15 [A1 - 20]	A1 - 15
	Spindle torque	N.m(ft.lbs)	5,143 (3,792)			
	Spindle through hole dia.	mm(inch)	181(7.125)		181(7.125) [275(10.83)]	181(7.125)
TRAVEL	Rapid traverse (X/Z)	m/min(ipm)	16/20(630/787)			
	Travel (X/Z)	mm(inch)	475/800(18.7/31.5)		475/1,600(18.7/63)	
	Feed motor (X/Z)	kW(hp)	7/6 (9.4/8)			
TURRET	Number of tool stations	st.	12			
	OD tool size	mm(inch)	□32 (□1.25)			
	Max. boring bar size	mm(inch)	80 (3)			
	Indexing time	sec	0.25/Step	0.35/Step	0.25/Step	0.35/Step
	Milling tool holder type	-	-	BMT85	-	BMT85
	Max. rotary tool spindle speed	rpm	-	3,000	-	3,000
	Rotary tool motor power	kW(hp)	-	7.5/11/15 (10/14.8/20.1)	-	7.5/11/15 (10/14.8/20.1)
TAILSTOCK	Tailstock travel	mm(inch)	Option		1,450(57.09)	
	Tailstock spindle diameter	mm(inch)	Option		180 (7.09)	
	Taper of tailstock spindle	-	Option		MT#6 (Built-in)	
	Tailstock spindle travel	mm(inch)	Option		150(5.91)	
BED TYPE	-	45° Slant				
ELECTRIC POWER SUPPLY	kVA	65				
REQUIRED FLOOR SPACE	mm(inch)	4,390(172.8)×2,379(93.7)			5,191(204.4)×2,379(93.7)	
MACHINE WEIGHT	kg(lbs)	11,500(25,353)	12,000(26,455)	15,300(33,371)	15,800(34,833)	
CONTROLLER		Fanuc Oi-TF Plus				

DESCRIPTION		NL 6000L [CL]	NL 6000LM	NL 6000XL [CXL]	NL 6000XLM	
CAPACITY	Swing over the bed	mm(inch)	1,030 (40.55)			
	Swing over the cross slide	mm(inch)	850 (33.46)			
	Max. machining diameter	mm(inch)	960(37.80)	900(35.43)	960(37.80)	900(35.43)
	Max. machining length	mm(inch)	2,250(88.58)	2,200(86.61)	3,250(127.95)	3,200(125.98)
	Chuck size	inch	24 [user scope]	24	24 [user scope]	24
	Bar working dia.	mm(inch)	165.5 (6.52) [-]	165.5 (6.52)	165.5 (6.52) [-]	165.5 (6.52)
SPINDLE	Spindle speed	rpm	1,200 [1,000]	1,200	1,200 [1,000]	1,200
	Spindle motor	kW(Hp)	37/55 (50/73)			
	Spindle nose	ASA	A1 - 15 [A1 - 20]	A1 - 15	A1 - 15 [A1 - 20]	A1 - 15
	Spindle torque	N.m(ft.lbs)	5,143 (3,792)			
	Spindle through hole dia.	mm(inch)	181(7.125) [275(10.83)]	181(7.125)	181(7.125) [275(10.83)]	181(7.125)
TRAVEL	Rapid traverse (X/Z)	m/min(ipm)	16/16(630/630)		16/10(630/394)	
	Travel (X/Z)	mm(inch)	475/2,300(18.7/90.55)		475/3,300(18.7/129.92)	
	Feed motor (X/Z)	kW(hp)	7/6 (9.4/8)			
TURRET	Number of tool stations	st.	12			
	OD tool size	mm(inch)	□32 (□1.25)			
	Max. boring bar size	mm(inch)	80 (3)			
	Indexing time	sec	0.25/Step	0.35/Step	0.25/Step	0.35/Step
	Milling tool holder type	-	-	BMT85	-	BMT85
	Max. rotary tool spindle speed	rpm	-	3,000	-	3,000
	Rotary tool motor power	kW(hp)	-	7.5/11/15 (10/14.8/20.1)	-	7.5/11/15 (10/14.8/20.1)
TAILSTOCK	Tailstock travel	mm(inch)	2,150(84.65)		3,150(124.02)	
	Tailstock spindle diameter	mm(inch)	180 (7.09)			
	Taper of tailstock spindle	-	MT#6 (Built-in)			
	Tailstock spindle travel	mm(inch)	150(5.91)			
BED TYPE	-	45° Slant				
ELECTRIC POWER SUPPLY	kVA	65				
REQUIRED FLOOR SPACE	mm(inch)	6,004(236.4)×2,389(94.1)			7,100(279.5)×2,657(104.6)	
MACHINE WEIGHT	kg(lbs)	17,300(38,140)	17,800(39,242)	19,800(43,652)	20,300(44,754)	
CONTROLLER		Fanuc Oi-TF Plus				



SMART Machine Tool Korea / R&D center / Factory

115-28, Techno valley 1-ro, Jillye-myeon, Gimhae-si,
Gyeongsangnam-do, Republic of Korea
TEL : +82-55-342-7972 | FAX : +82-55-342-7970
E-mail : smtk@smtkor.com
www.smtkor.com

SMART Machine Tool America

N25W23287 Paul Rd, Pewaukee, WI 53072, USA
TEL : 1-855-637-3320
FAX : 1-262-521-1244
www.smartmachinetool.com